

REVISIONS				
REV	DATE	DESCRIPTION	CHG	APPR

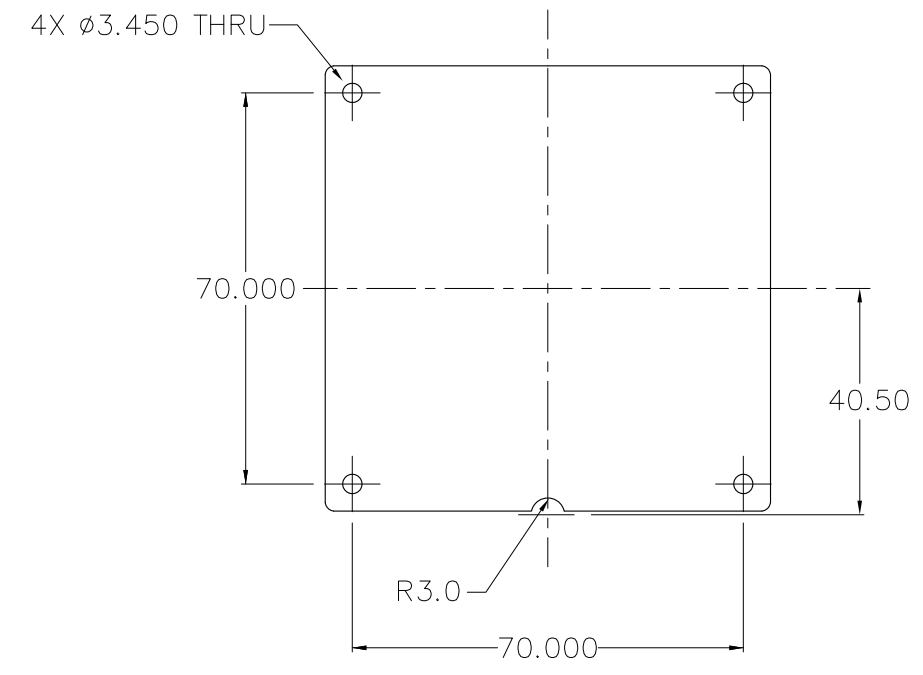
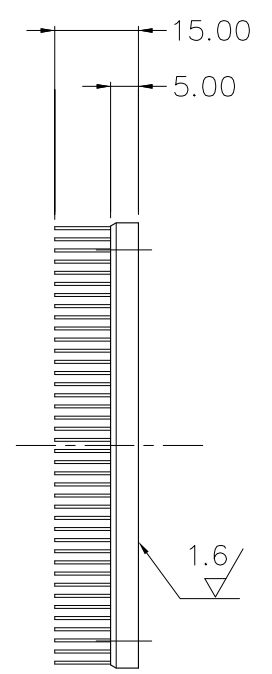
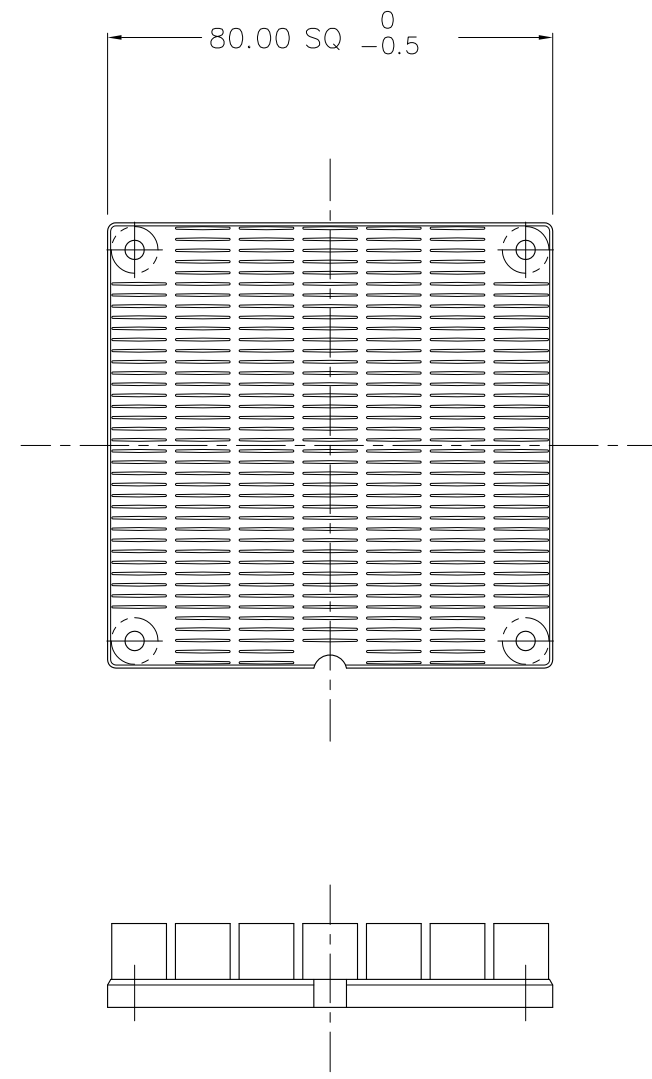

NOTES : UNLESS OTHERWISE SPECIFIED

1. INTERPRET DIMENSIONS AND TOLERANCES PER ANSI Y14.5M
2. ALL DIMENSIONS ARE IN MILLIMETERS.
3. MATERIAL : ALUMINUM 6063
4. FINISH : *****
5. TOLERANCES :

.XX	±0.254
.XXX	±0.127
ANGLES	± 1°
6. REMOVE ALL BURRS AND BREAK SHARP EDGES. UNSPECIFIED CORNER R0.5 MAX OR C0.5 MAX
7. A BEND OF THE FIN: THE FINS MUST NOT CONTACT.
8. BASED ON ALPHA "*****" SERIES HEAT SINK
9. FIN REMOVAL MARKS HEIGHT 0.3MAX.

ITEM	PART NO.	PART NAME	REMARK	Q'TY
ALPHA CO.,LTD.			CSTM'R'S PART NO.	
		MATERIAL	NAME	
SCALE 1 : 1		APPR & CHCK	PART NO. & DWG NO.	REV
DATE		DSGN & DWG	Sample	
RDCTN:			LOFF:	