

QuickSet Series
QZL

ALPHA

ALPHA

QuickSet HeatSink

QZL35

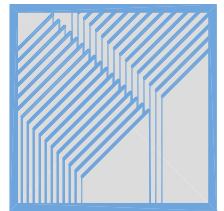

DIM

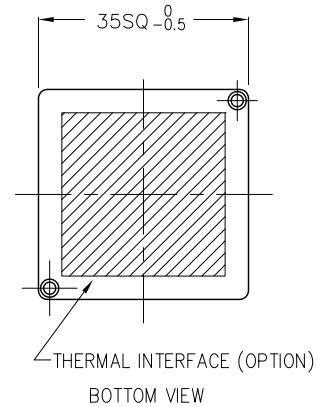
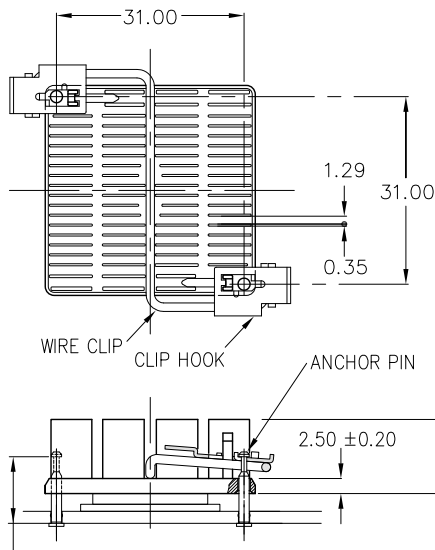

ANCHOR PIN LENGTH : CAN SELECT 8.00, 11.00, 13.00, OR 16.00.

- 8.00 : ANCR-8
- 11.00 : ANCR-11
- 13.00 : ANCR-13
- 16.00 : ANCR-16

ATTACHMENT FORCE : REFER TO THE ● CLIP FORCE.

- MATERIAL
- HEATSINK : A6063 BLACK ANODIZE
- WIRE CLIP : SW-C NICKEL PRECOATED
- HOOK : STAINLESS STEEL 304
- ANCHOR : STAINLESS STEEL 303

DIMENSIONS : mm

BASIC HEATSINK MODEL NUMBER	OVERALL HEIGHT [h]	BASIC HEATSINK WEIGHT (grams)	FEATURES
QZL35-10B	10	12.7	FOR FORCED CONVECTION HIGH PERFORMANCE HEATSINK.
QZL35-12B	12	13.9	

● PCB HOLE PATTERN & SUGGESTED KEEP-OUT AREA

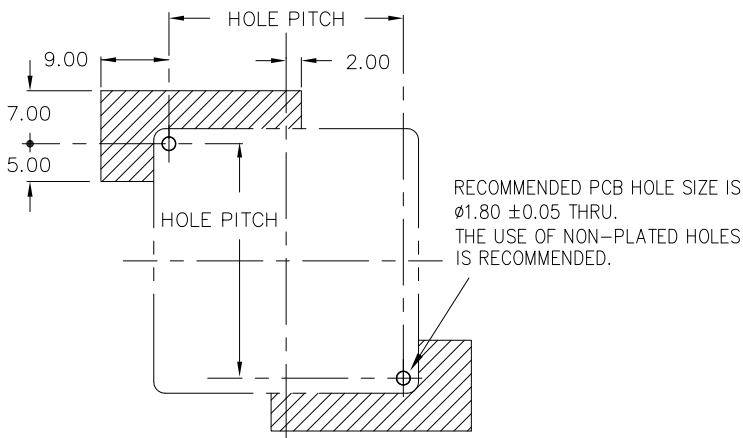

● CLIP FORCE

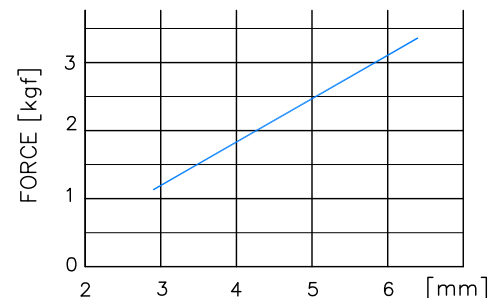

- ANCR-8 : CHIP HEIGHT + PCB THK + 3.0
- ANCR-11 : CHIP HEIGHT + PCB THK
- ANCR-13 : CHIP HEIGHT + PCB THK - 2.0
- ANCR-16 : CHIP HEIGHT + PCB THK - 5.0

Alpha Company Ltd.

256-1 UEDA, NUMAZU-CITY SHIZUOKA-PREF., JAPAN
 PHONE +81(55)966 0789
 FAX +81(55)966 9192
 E mail : alpha@micforg.co.jp
 URL : http://www.micforg.co.jp

Alpha Novatech, Inc. - a subsidiary of Alpha Company.

473 Sapena Ct. #12 Santa Clara, CA 95054 USA
 PHONE +1(408)567-8082
 FAX +1(408)567-8053
 E mail : sales@alphanovatech.com
 URL : http://www.alphanovatech.com

DATA

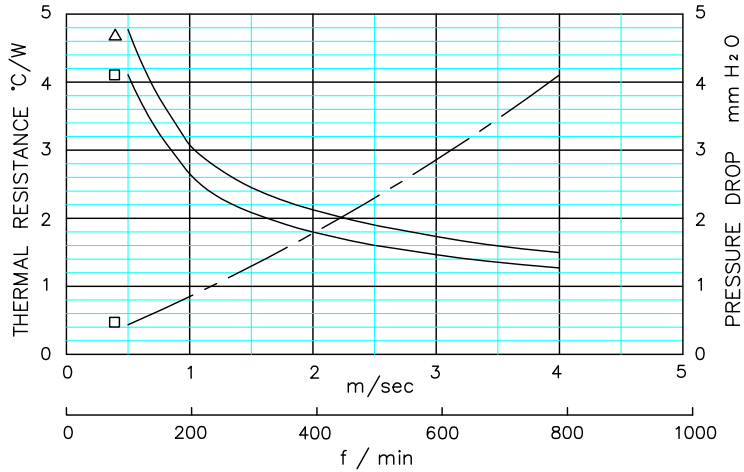

△ QZL35-10B
 □ QZL35-12B

- DUCTED CONDITION
 DUMMY HEATER SIZE: 12.7 SQ
 THERMAL RESISTANCE _____
 PRESURE DROP - - - - -
- BASED ON ALPHA'S STANDARD TEST PROCEDURE.
 REFER TO TECHNICAL INFORMATION.

AIR VELOCITY: DUCTED CONDITION

REF



MODEL NAME INFORMATION

TO BUILD PART NUMBER, PLEASE VISIT OUR WEBSITE www.micforg.co.jp OR CONTACT ALPHA SALES.

Alpha Company Ltd.

256-1 UEDA, NUMAZU-CITY SHIZUOKA-PREF., JAPAN
 PHONE +81(55)966 0789
 FAX +81(55)966 9192
 E mail : alpha@micforg.co.jp
 URL : <http://www.micforg.co.jp>

Alpha Novatech, Inc. - a subsidiary of Alpha Company.

473 Sapena Ct. #12 Santa Clara, CA 95054 USA
 PHONE +1(408)567-8082
 FAX +1(408)567-8053
 E mail : sales@alphanovatech.com
 URL : <http://www.alphanovatech.com>

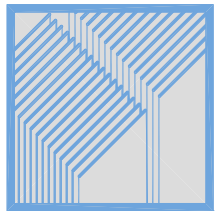

DIM

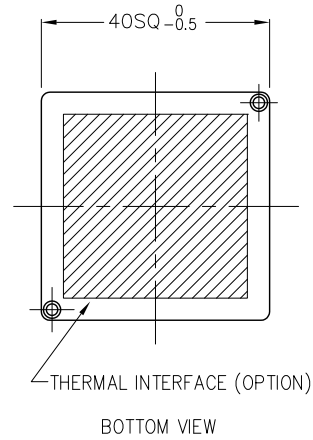
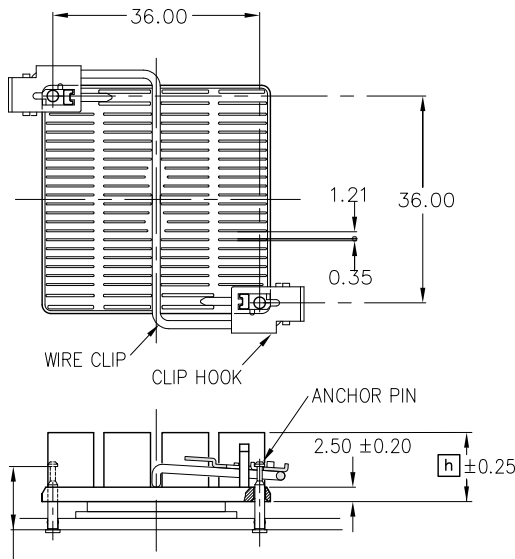

ANCHOR PIN LENGTH : CAN SELECT 8.00, 11.00, 13.00, OR 16.00.

8.00 : ANCR-8

11.00 : ANCR-11

13.00 : ANCR-13

16.00 : ANCR-16

ATTACHMENT FORCE : REFER TO THE ● CLIP FORCE.

MATERIAL

HEATSINK : A6063 BLACK ANODIZE

WIRE CLIP : SW-C NICKEL PRECOATED

HOOK : STAINLESS STEEL 304

ANCHOR : STAINLESS STEEL 303

DIMENSIONS : mm

BASIC HEATSINK MODEL NUMBER	OVERALL HEIGHT [h]	BASIC HEATSINK WEIGHT (grams)	FEATURES
QZL40-10B	10	17.1	FOR FORCED CONVECTION HIGH PERFORMANCE HEATSINK.
QZL40-12B	12	18.9	

● PCB HOLE PATTERN & SUGGESTED KEEP-OUT AREA

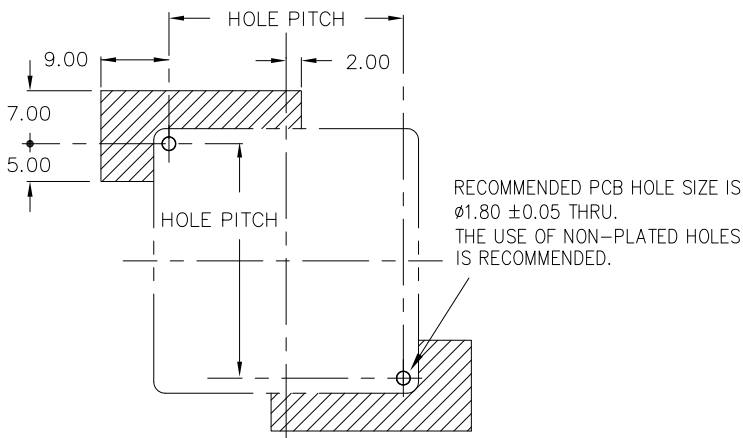

● CLIP FORCE

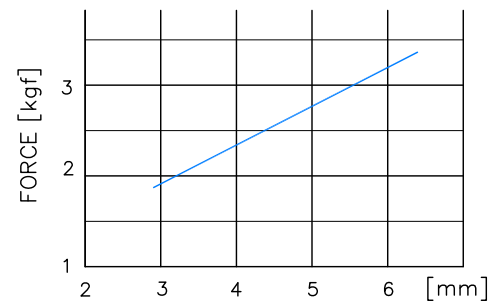

ANCR-8 : CHIP HEIGHT + PCB THK + 3.0

ANCR-11 : CHIP HEIGHT + PCB THK

ANCR-13 : CHIP HEIGHT + PCB THK - 2.0

ANCR-16 : CHIP HEIGHT + PCB THK - 5.0

Alpha Company Ltd.

256-1 UEDA, NUMAZU-CITY SHIZUOKA-PREF., JAPAN

PHONE +81(55)966 0789

FAX +81(55)966 9192

E mail : alpha@micforg.co.jp

URL : http://www.micforg.co.jp

Alpha Novatech, Inc. - a subsidiary of Alpha Company.

473 Sapena Ct. #12 Santa Clara, CA 95054 USA

PHONE +1(408)567-8082

FAX +1(408)567-8053

E mail : sales@alphanovatech.com

URL : http://www.alphanovatech.com

DATA

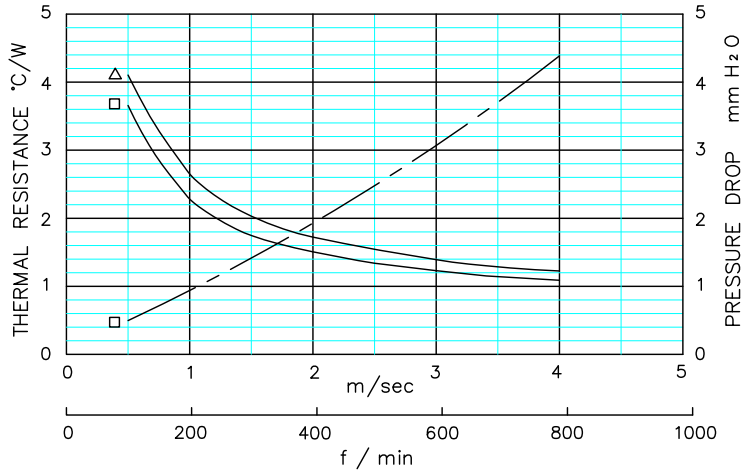

△ QZL40-10B
 □ QZL40-12B

● DUCTED CONDITION
 DUMMY HEATER SIZE: 12.7 SQ
 THERMAL RESISTANCE _____
 PRESURE DROP - - - - -
 ■ BASED ON ALPHA'S STANDARD TEST PROCEDURE.
 REFER TO TECHNICAL INFORMATION.

AIR VELOCITY: DUCTED CONDITION

REF



MODEL NAME INFORMATION
 TO BUILD PART NUMBER, PLEASE VISIT OUR WEBSITE www.micforg.co.jp OR CONTACT ALPHA SALES.

Alpha Company Ltd.

256-1 UEDA, NUMAZU-CITY SHIZUOKA-PREF., JAPAN
 PHONE +81(55)966 0789
 FAX +81(55)966 9192
 E mail : alpha@micforg.co.jp
 URL : <http://www.micforg.co.jp>

Alpha Novatech, Inc. - a subsidiary of Alpha Company.

473 Sapena Ct. #12 Santa Clara, CA 95054 USA
 PHONE +1(408)567-8082
 FAX +1(408)567-8053
 E mail : sales@alphanovatech.com
 URL : <http://www.alphanovatech.com>

ALPHA

QuickSet HeatSink

QZL45

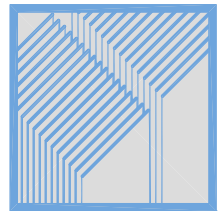

DIM

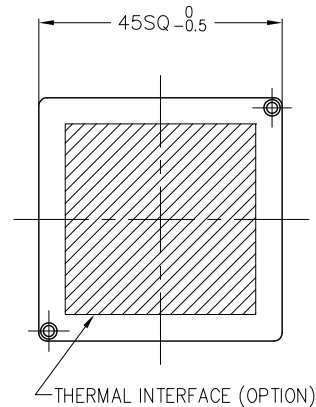
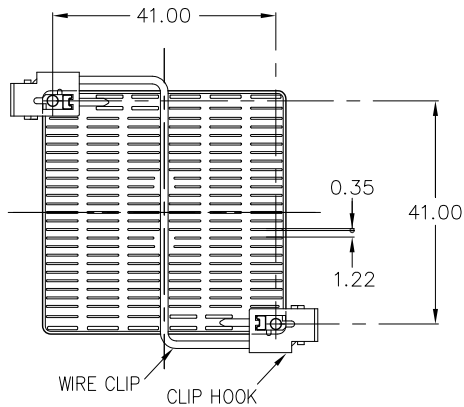

BOTTOM VIEW

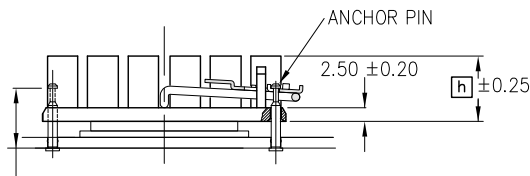

ANCHOR PIN LENGTH : CAN SELECT 8.00, 11.00, 13.00, OR 16.00.

- 8.00 : ANCR-8
- 11.00 : ANCR-11
- 13.00 : ANCR-13
- 16.00 : ANCR-16

ATTACHMENT FORCE : REFER TO THE ● CLIP FORCE.

- MATERIAL
- HEATSINK : A6063 BLACK ANODIZE
- WIRE CLIP : SW-C NICKEL PRECOATED
- HOOK : STAINLESS STEEL 304
- ANCHOR : STAINLESS STEEL 303

DIMENSIONS : mm

BASIC HEATSINK MODEL NUMBER	OVERALL HEIGHT [h]	BASIC HEATSINK WEIGHT (grams)	FEATURES
QZL45-10B	10	21.5	FOR FORCED CONVECTION HIGH PERFORMANCE HEATSINK.
QZL45-12B	12	23.5	

● PCB HOLE PATTERN & SUGGESTED KEEP-OUT AREA

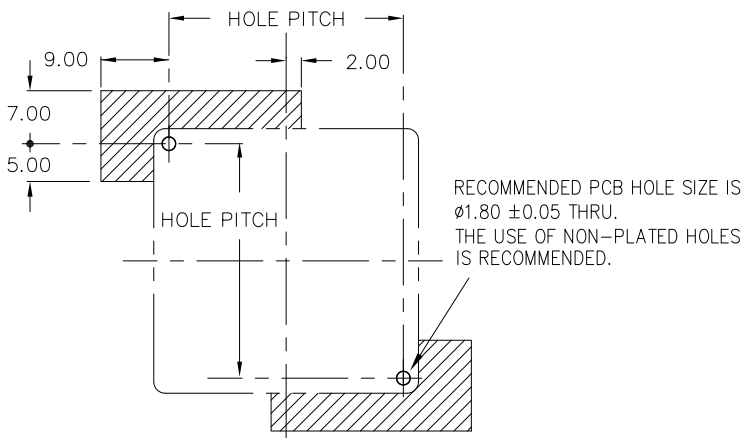

● CLIP FORCE

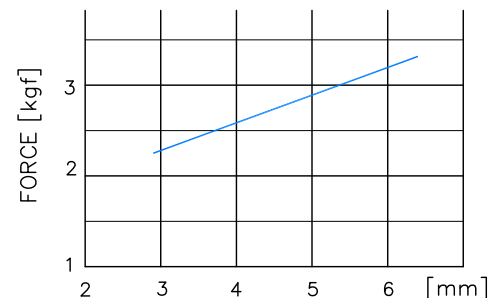

- ANCR-8 : CHIP HEIGHT + PCB THK + 3.0
- ANCR-11 : CHIP HEIGHT + PCB THK
- ANCR-13 : CHIP HEIGHT + PCB THK - 2.0
- ANCR-16 : CHIP HEIGHT + PCB THK - 5.0

Alpha Company Ltd.

256-1 UEDA, NUMAZU-CITY SHIZUOKA-PREF., JAPAN
 PHONE +81(55)966 0789
 FAX +81(55)966 9192
 E mail : alpha@micforg.co.jp
 URL : http://www.micforg.co.jp

Alpha Novatech, Inc. - a subsidiary of Alpha Company.

473 Sapena Ct. #12 Santa Clara, CA 95054 USA
 PHONE +1(408)567-8082
 FAX +1(408)567-8053
 E mail : sales@alphanovatech.com
 URL : http://www.alphanovatech.com

DATA

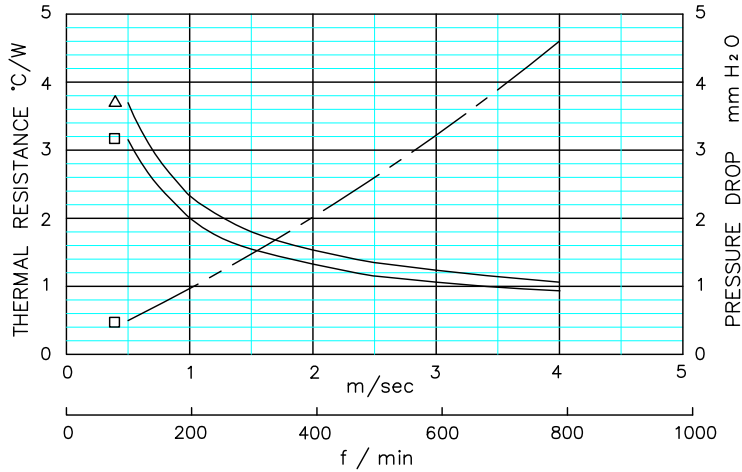

- △ QZL45-10B
- QZL45-12B

- DUCTED CONDITION
DUMMY HEATER SIZE: 12.7 SQ
THERMAL RESISTANCE _____
PRESURE DROP - - - - -
- BASED ON ALPHA'S STANDARD TEST PROCEDURE.
REFER TO TECHNICAL INFORMATION.

AIR VELOCITY: DUCTED CONDITION

REF



MODEL NAME INFORMATION

TO BUILD PART NUMBER, PLEASE VISIT OUR WEBSITE www.micforg.co.jp OR CONTACT ALPHA SALES.

Alpha Company Ltd.

256-1 UEDA, NUMAZU-CITY SHIZUOKA-PREF., JAPAN
 PHONE +81(55)966 0789
 FAX +81(55)966 9192
 E mail : alpha@micforg.co.jp
 URL : <http://www.micforg.co.jp>

Alpha Novatech, Inc. - a subsidiary of Alpha Company.

473 Sapena Ct. #12 Santa Clara, CA 95054 USA
 PHONE +1(408)567-8082
 FAX +1(408)567-8053
 E mail : sales@alphanovatech.com
 URL : <http://www.alphanovatech.com>

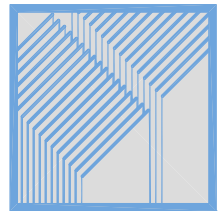

DIM

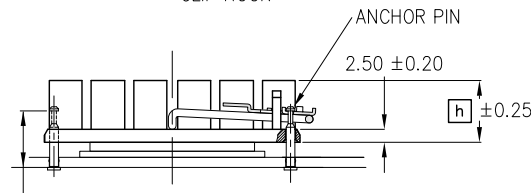
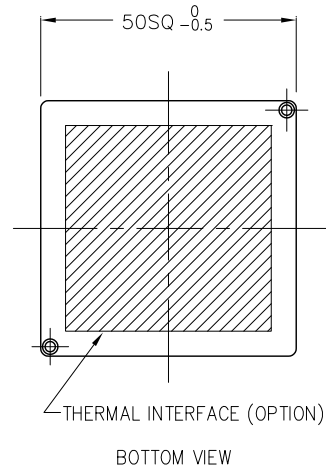
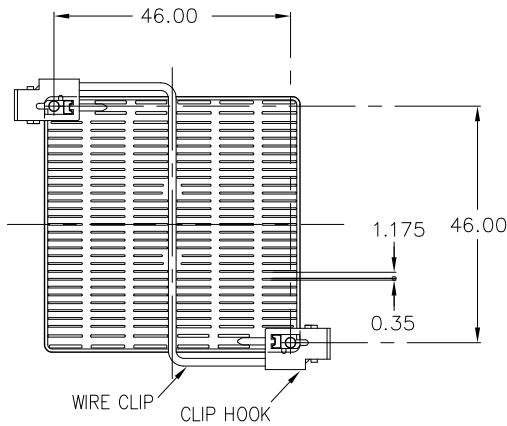

ANCHOR PIN LENGTH : CAN SELECT 8.00, 11.00, 13.00, OR 16.00.
 8.00 : ANCR-8
 11.00 : ANCR-11
 13.00 : ANCR-13
 16.00 : ANCR-16
 ATTACHMENT FORCE : REFER TO THE ● CLIP FORCE.

MATERIAL
 HEATSINK : A6063 BLACK ANODIZE
 WIRE CLIP : SW-C NICKEL PRECOATED
 HOOK : STAINLESS STEEL 304
 ANCHOR : STAINLESS STEEL 303

DIMENSIONS : mm

BASIC HEATSINK MODEL NUMBER	OVERALL HEIGHT [h]	BASIC HEATSINK WEIGHT (grams)	FEATURES
QZL50-10B	10	27.4	FOR FORCED CONVECTION HIGH PERFORMANCE HEATSINK.
QZL50-12B	12	30.4	

● PCB HOLE PATTERN & SUGGESTED KEEP-OUT AREA

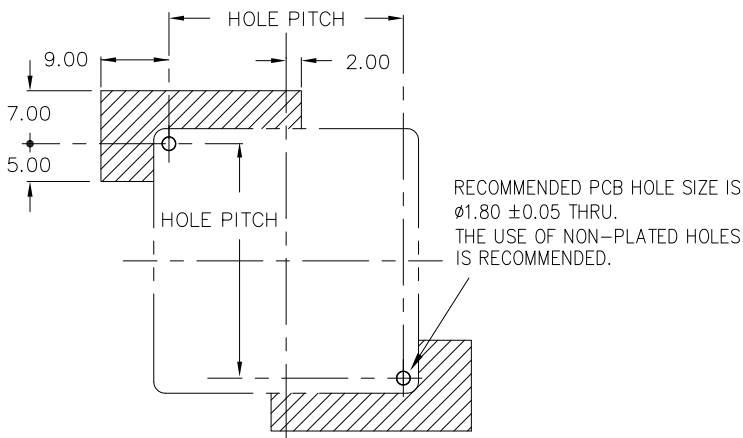

● CLIP FORCE

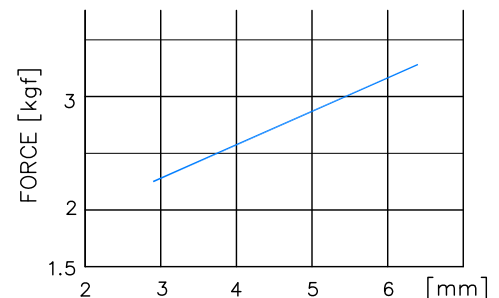

ANCR-8 : CHIP HEIGHT + PCB THK + 3.0
 ANCR-11 : CHIP HEIGHT + PCB THK
 ANCR-13 : CHIP HEIGHT + PCB THK - 2.0
 ANCR-16 : CHIP HEIGHT + PCB THK - 5.0

Alpha Company Ltd.

256-1 UEDA, NUMAZU-CITY SHIZUOKA-PREF., JAPAN
 PHONE +81(55)966 0789
 FAX +81(55)966 9192
 E mail : alpha@micforg.co.jp
 URL : http://www.micforg.co.jp

Alpha Novatech, Inc. - a subsidiary of Alpha Company.

473 Sapena Ct. #12 Santa Clara, CA 95054 USA
 PHONE +1(408)567-8082
 FAX +1(408)567-8053
 E mail : sales@alphanovatech.com
 URL : http://www.alphanovatech.com

DATA

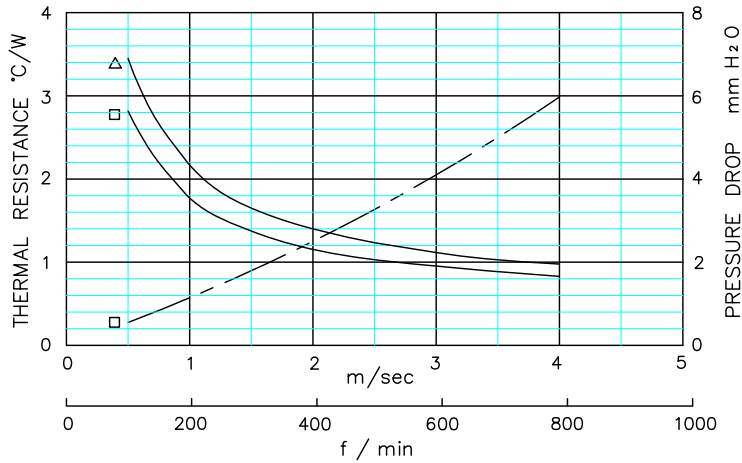

△ QZL50-10B
□ QZL50-12B

- DUCTED CONDITION
DUMMY HEATER SIZE: 12.7 SQ
THERMAL RESISTANCE _____
PRESURE DROP - - - - -
- BASED ON ALPHA'S STANDARD TEST PROCEDURE.
REFER TO TECHNICAL INFORMATION.

AIR VELOCITY: DUCTED CONDITION

REF



MODEL NAME INFORMATION

TO BUILD PART NUMBER, PLEASE VISIT OUR WEBSITE www.micforg.co.jp OR CONTACT ALPHA SALES.

Alpha Company Ltd.

256-1 UEDA, NUMAZU-CITY SHIZUOKA-PREF., JAPAN
PHONE +81(55)966 0789
FAX +81(55)966 9192
E mail : alpha@micforg.co.jp
URL : <http://www.micforg.co.jp>

Alpha Novatech, Inc. - a subsidiary of Alpha Company.

473 Sapena Ct. #12 Santa Clara, CA 95054 USA
PHONE +1(408)567-8082
FAX +1(408)567-8053
E mail : sales@alphanovatech.com
URL : <http://www.alphanovatech.com>

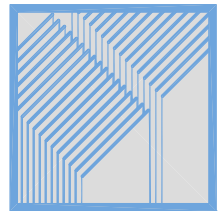

DIM

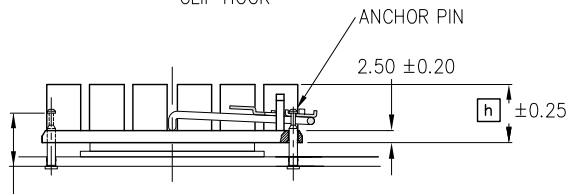
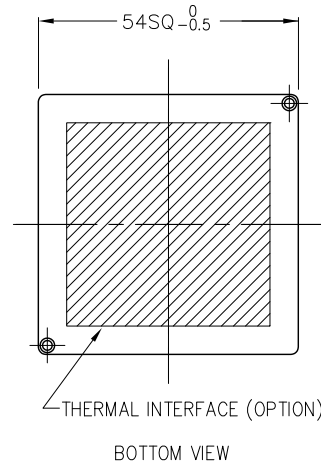
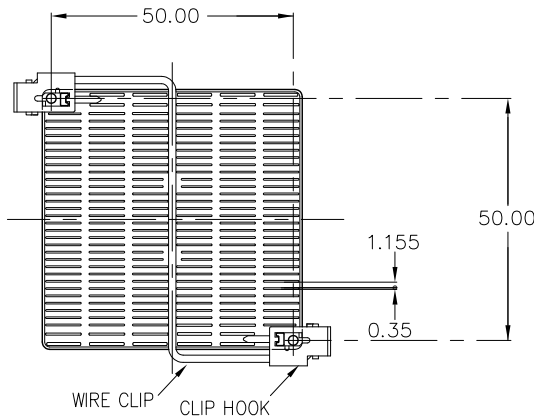

ANCHOR PIN LENGTH : CAN SELECT 8.00, 11.00, 13.00, OR 16.00.
 8.00 : ANCR-8
 11.00 : ANCR-11
 13.00 : ANCR-13
 16.00 : ANCR-16

ATTACHMENT FORCE : REFER TO THE ● CLIP FORCE.

MATERIAL
 HEATSINK : A6063 BLACK ANODIZE
 WIRE CLIP : SW-C NICKEL PRECOATED
 HOOK : STAINLESS STEEL 304
 ANCHOR : STAINLESS STEEL 303

DIMENSIONS : mm

BASIC HEATSINK MODEL NUMBER	OVERALL HEIGHT [h]	BASIC HEATSINK WEIGHT (grams)	FEATURES
QZL54-10B	10	32.5	FOR FORCED CONVECTION HIGH PERFORMANCE HEATSINK.
QZL54-12B	12	36.1	

● PCB HOLE PATTERN & SUGGESTED KEEP-OUT AREA

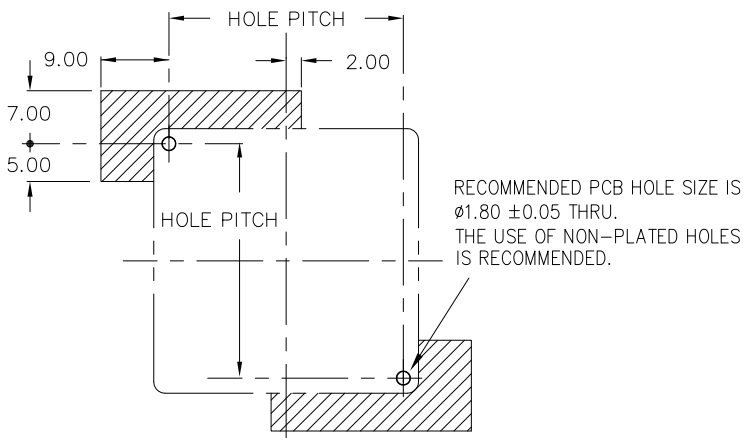

● CLIP FORCE

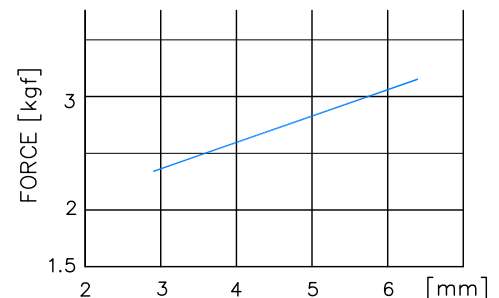

ANCR-8 : CHIP HEIGHT + PCB THK + 3.0
 ANCR-11 : CHIP HEIGHT + PCB THK
 ANCR-13 : CHIP HEIGHT + PCB THK - 2.0
 ANCR-16 : CHIP HEIGHT + PCB THK - 5.0

Alpha Company Ltd.

256-1 UEDA, NUMAZU-CITY SHIZUOKA-PREF., JAPAN
 PHONE +81(55)966 0789
 FAX +81(55)966 9192
 E mail : alpha@micforg.co.jp
 URL : http://www.micforg.co.jp

Alpha Novatech, Inc. - a subsidiary of Alpha Company.

473 Sapena Ct. #12 Santa Clara, CA 95054 USA
 PHONE +1(408)567-8082
 FAX +1(408)567-8053
 E mail : sales@alphanovatech.com
 URL : http://www.alphanovatech.com

DATA

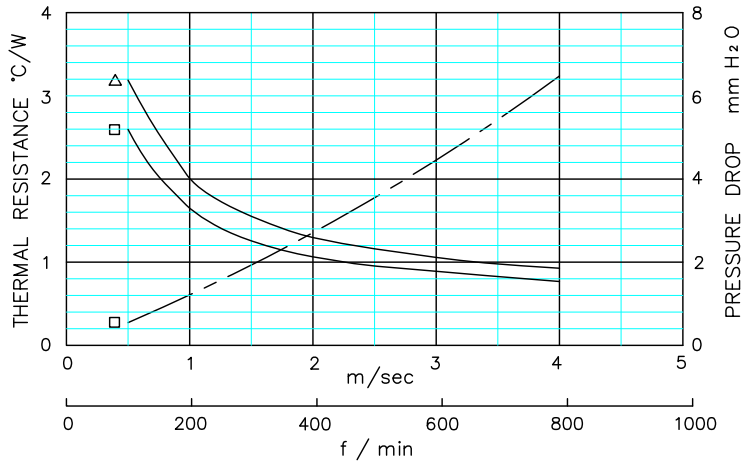

△ QZL54-10B
□ QZL54-12B

- DUCTED CONDITION
DUMMY HEATER SIZE: 12.7 SQ
THERMAL RESISTANCE _____
PRESURE DROP - - - - -
- BASED ON ALPHA'S STANDARD TEST PROCEDURE.
REFER TO TECHNICAL INFORMATION.

AIR VELOCITY: DUCTED CONDITION

REF



MODEL NAME INFORMATION

TO BUILD PART NUMBER, PLEASE VISIT OUR WEBSITE www.micforg.co.jp OR CONTACT ALPHA SALES.

Alpha Company Ltd.

256-1 UEDA, NUMAZU-CITY SHIZUOKA-PREF., JAPAN
PHONE +81(55)966 0789
FAX +81(55)966 9192
E mail : alpha@micforg.co.jp
URL : <http://www.micforg.co.jp>

Alpha Novatech, Inc. - a subsidiary of Alpha Company.

473 Sapena Ct. #12 Santa Clara, CA 95054 USA
PHONE +1(408)567-8082
FAX +1(408)567-8053
E mail : sales@alphanovatech.com
URL : <http://www.alphanovatech.com>

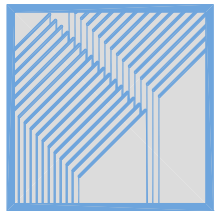

DIM

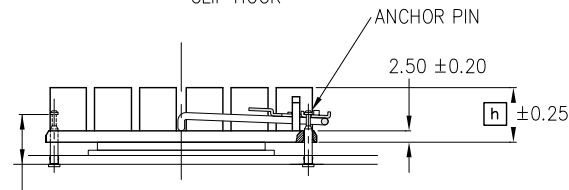
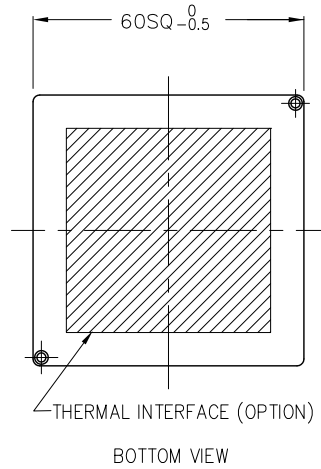
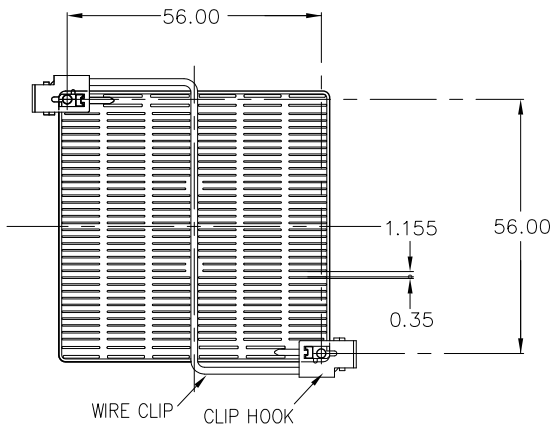

ANCHOR PIN LENGTH : CAN SELECT 8.00, 11.00, 13.00, OR 16.00.
 8.00 : ANCR-8
 11.00 : ANCR-11
 13.00 : ANCR-13
 16.00 : ANCR-16

ATTACHMENT FORCE : REFER TO THE ● CLIP FORCE.

MATERIAL
 HEATSINK : A6063 BLACK ANODIZE
 WIRE CLIP : SW-C NICKEL PRECOATED
 HOOK : STAINLESS STEEL 304
 ANCHOR : STAINLESS STEEL 303

DIMENSIONS : mm

BASIC HEATSINK MODEL NUMBER	OVERALL HEIGHT [h]	BASIC HEATSINK WEIGHT (grams)	FEATURES
QZL60-10B	10	39.7	FOR FORCED CONVECTION HIGH PERFORMANCE HEATSINK.
QZL60-12B	12	44.1	

● PCB HOLE PATTERN & SUGGESTED KEEP-OUT AREA

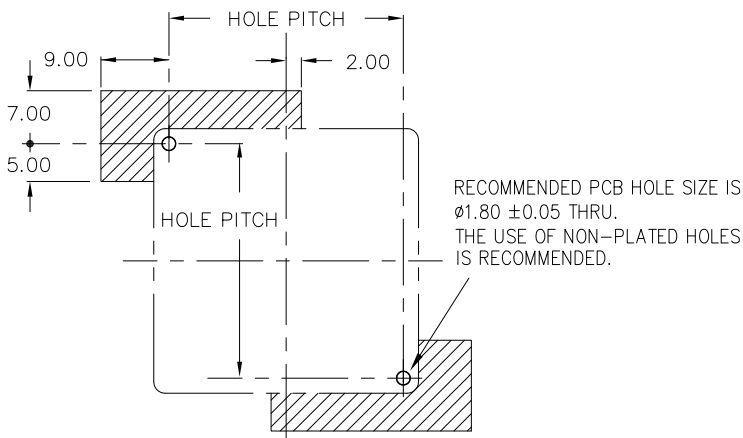

● CLIP FORCE

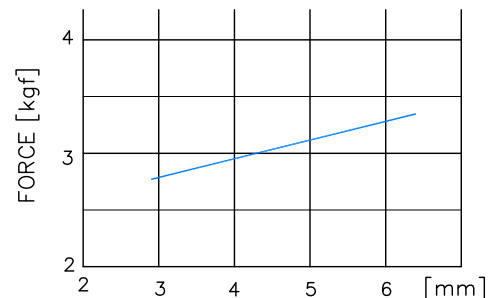

ANCR-8 : CHIP HEIGHT + PCB THK + 3.0
 ANCR-11 : CHIP HEIGHT + PCB THK
 ANCR-13 : CHIP HEIGHT + PCB THK - 2.0
 ANCR-16 : CHIP HEIGHT + PCB THK - 5.0

Alpha Company Ltd.

256-1 UEDA, NUMAZU-CITY SHIZUOKA-PREF., JAPAN
 PHONE +81(55)966 0789
 FAX +81(55)966 9192
 E mail : alpha@micforg.co.jp
 URL : http://www.micforg.co.jp

Alpha Novatech, Inc. - a subsidiary of Alpha Company.

473 Sapena Ct. #12 Santa Clara, CA 95054 USA
 PHONE +1(408)567-8082
 FAX +1(408)567-8053
 E mail : sales@alphanovatech.com
 URL : http://www.alphanovatech.com

DATA

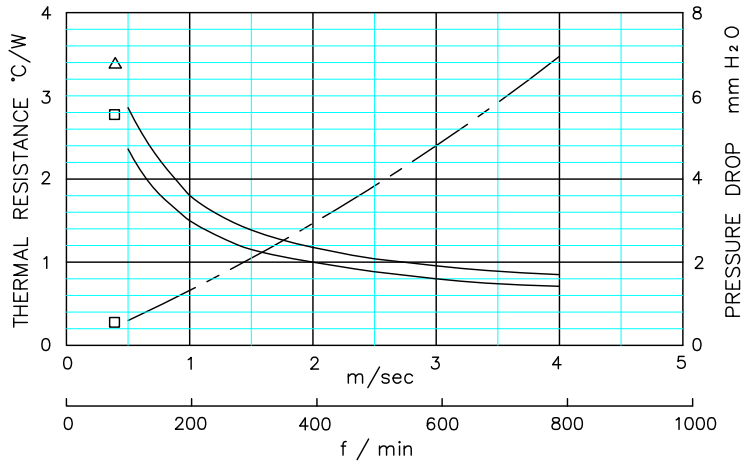

△ QZL60-10B
 □ QZL60-12B

● DUCTED CONDITION
 DUMMY HEATER SIZE: 12.7 SQ
 THERMAL RESISTANCE _____
 PRESURE DROP - - - - -
 ■ BASED ON ALPHA'S STANDARD TEST PROCEDURE.
 REFER TO TECHNICAL INFORMATION.

AIR VELOCITY: DUCTED CONDITION

REF



MODEL NAME INFORMATION
 TO BUILD PART NUMBER, PLEASE VISIT OUR WEBSITE www.micforg.co.jp OR CONTACT ALPHA SALES.

Alpha Company Ltd.

256-1 UEDA, NUMAZU-CITY SHIZUOKA-PREF., JAPAN
 PHONE +81(55)966 0789
 FAX +81(55)966 9192
 E mail : alpha@micforg.co.jp
 URL : <http://www.micforg.co.jp>

Alpha Novatech, Inc. - a subsidiary of Alpha Company.

473 Sapena Ct. #12 Santa Clara, CA 95054 USA
 PHONE +1(408)567-8082
 FAX +1(408)567-8053
 E mail : sales@alphanovatech.com
 URL : <http://www.alphanovatech.com>