

REVISIONS				
REV	DATE	DESCRIPTION	CHG	APPR
PRODUCTION RELEASE				

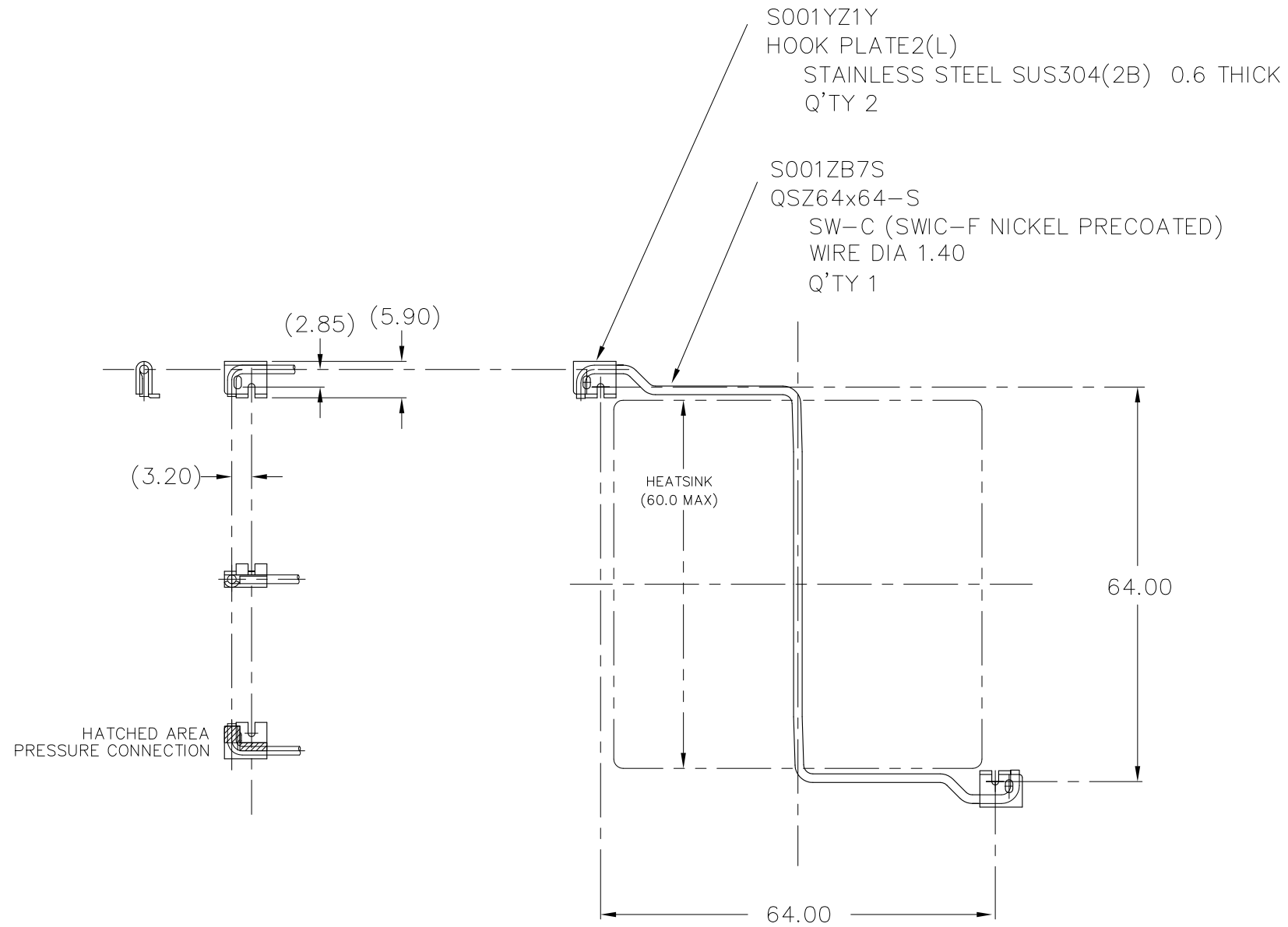

ANCHOR LAYOUT ON BOARD
REQUIRES $\phi 1.80 \pm 0.05$ THRU HOLES
FOR ANCHORS IN BOARD.

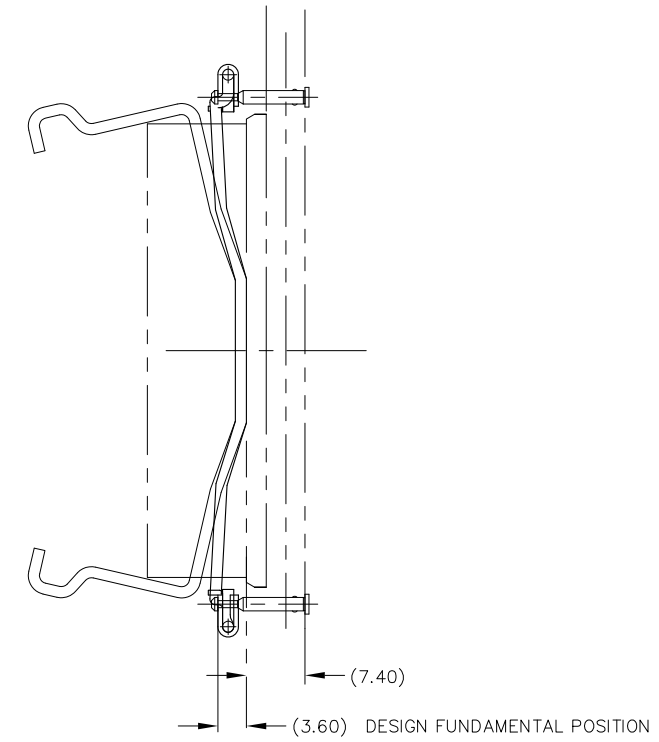

- NOTES : UNLESS OTHERWISE SPECIFIED
1. INTERPRET DIMENSIONS AND TOLERANCES PER ANSI Y14.5M
 2. ALL DIMENSIONS ARE IN MILLIMETERS.
 3. TOLERANCES :
 .XX ± 0.254
 .XXX ± 0.127
 ANGLES $\pm 3^\circ$

ITEM	PART NO.	PART NAME	REMARK	Q'TY
ALPHA CO.,LTD.		CSTM'R'S PART NO.		
	MATERIAL		NAME	QSZ64x64
SCALE 1 : 1	APPR & CHCK Y.SUZUKI		PART NO. & DWG NO.	REV
DATE JAN 14 2011	DSGN & DWG Y.SUZUKI		S001ZB7R	
RDCTN:			LOFF:	