

REVISIONS				
REV	DATE	DESCRIPTION	CHG	APPR
PRODUCTION RELEASE				

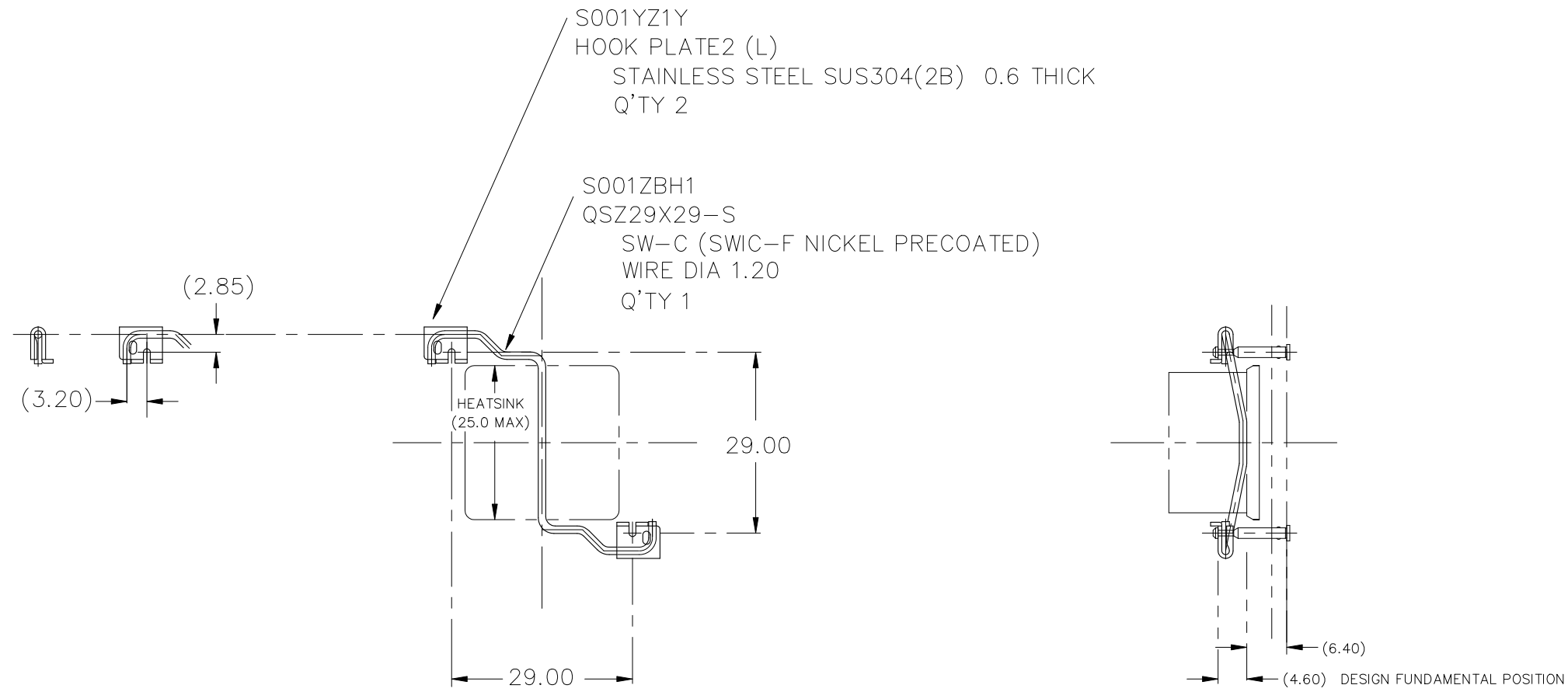

ANCHOR LAYOUT ON BOARD
REQUIRES $\phi 1.80 \pm 0.05$ THRU HOLES
FOR ANCHORS IN BOARD.

- NOTES: UNLESS OTHERWISE SPECIFIED
1. INTERPRET DIMENSIONS AND TOLERANCES PER ANSI Y14.5M
 2. ALL DIMENSIONS ARE IN MILLIMETERS.
 3. TOLERANCES :

.XX	± 0.254
.XXX	± 0.127
ANGLES	$\pm 3^\circ$

ITEM	PART NO.	PART NAME	REMARK	Q'TY
ALPHA CO.,LTD.			CSTM'R'S PART NO.	
		MATERIAL	NAME	QSZ29X29
SCALE 1 : 1		APPR & CHCK Y.SUZUKI	PART NO. & DWG NO.	REV
DATE APR 10 2018		DSGN & DWG Y.SUZUKI	S001ZBGZ	
RDCTN:			LOFF:	