

REVISIONS				
REV	DATE	DESCRIPTION	CHG	APPR

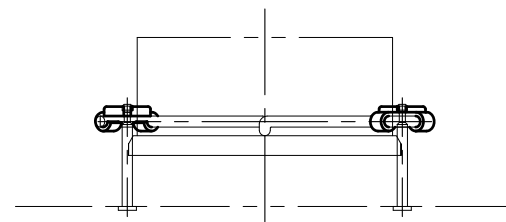
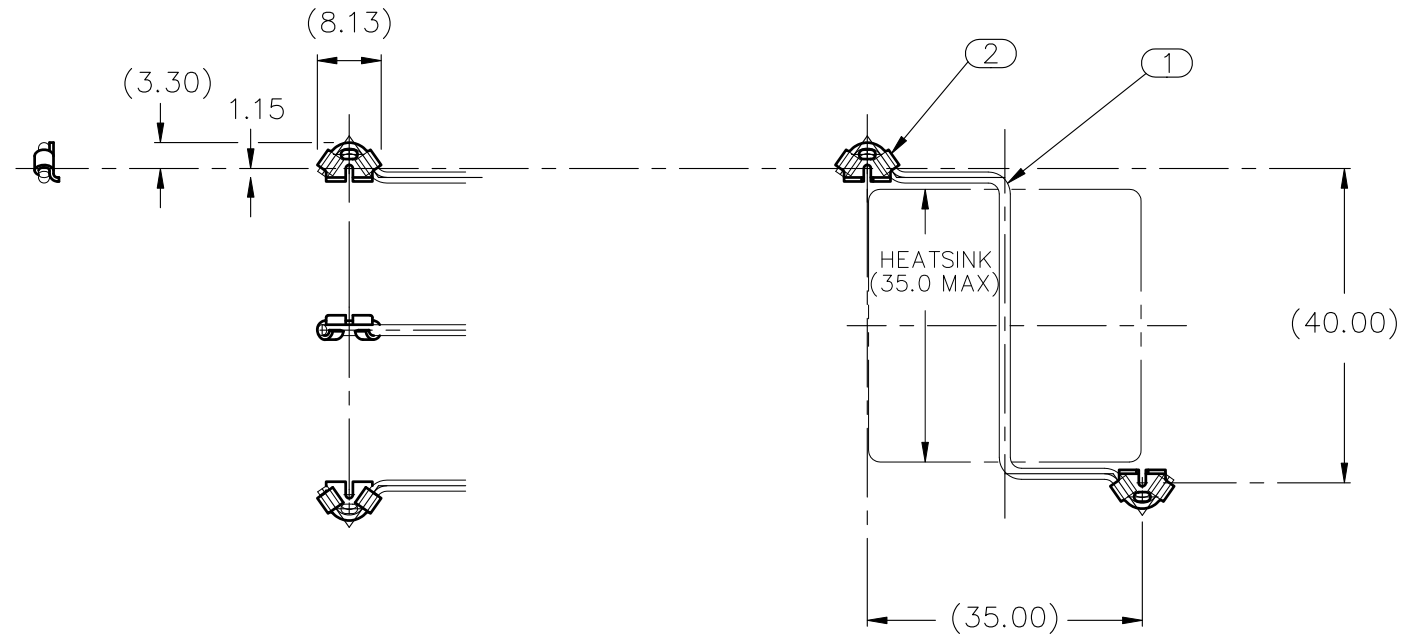

ANCHOR LAYOUT ON BOARD
REQUIRES $\phi 1.50 \pm 0.05$ THRU HOLES
FOR ANCHORS IN BOARD.

- NOTES : UNLESS OTHERWISE SPECIFIED
 1. INTERPRET DIMENSIONS AND TOLERANCES PER ANSI Y14.5M
 2. ALL DIMENSIONS ARE IN MILLIMETERS.
 3. TOLERANCES :
 .XX ± 0.254
 .XXX ± 0.127
 ANGLES $\pm 5^\circ$

ITEM	PART NO.	PART NAME	REMARK	Q'TY
②	S001YZ6Z	R-HOOK PLATE DIA1.4	STAINLESS STEEL SUS304(2B) 0.6 THICK	2
①	S001ZBLR	CQZL35-40-S	SW-C (SWIC-F NICKEL PRECOATED) WIRE DIA 1.40	1

ALPHA CO.,LTD.		CSTM'R'S PART NO.		
	MATERIAL	NAME CQZL35-40		
SCALE 1 : 1	APPR & CHCK T. SUZUKI	PART NO. & DWG NO. S001ZBLT		REV
DATE JAN 10, 2023	DSGN & DWG T. SUZUKI	RDCTN:	LOFF:	