

REVISIONS		
REV	DATE	DESCRIPTION
		REASSIGN PART# (WAS S001ZADM-REV/B)

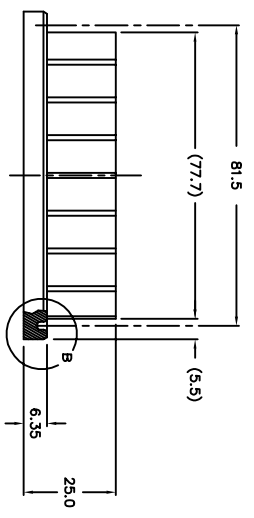

SCALE 4:1
 DETALE B

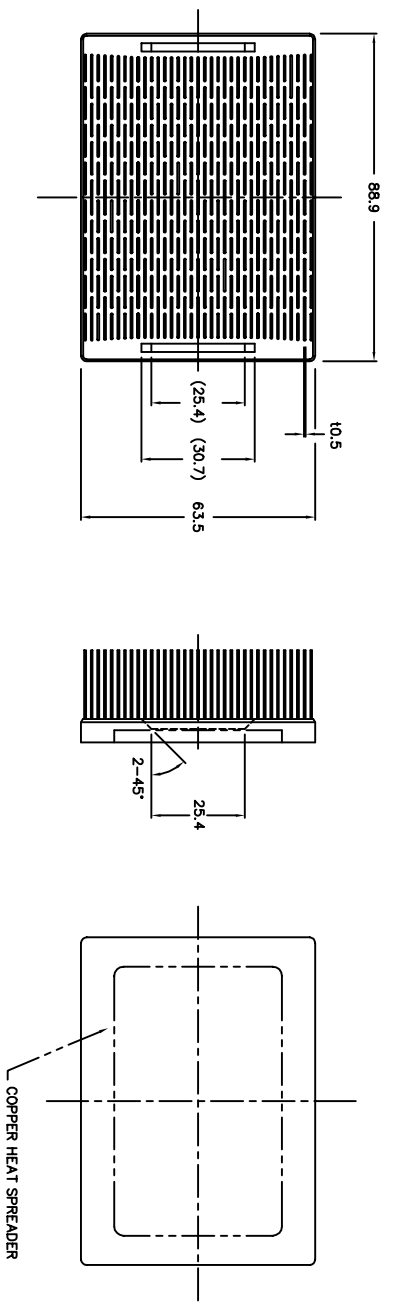
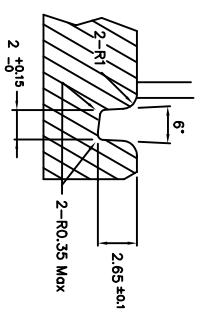

- NOTES : UNLESS OTHERWISE SPECIFIED
 1. INTERPRET DIMENSIONS AND TOLERANCES PER ANSI Y14.5M-1982
 2. ALL DIMENSIONS ARE IN MILLIMETERS.
 3. MATERIAL : ALUMINIUM 6063
 COPPER : C1100 OR C1020
 4. FINISH : BLACK ANODIZE
 EXCEPT BASE SURFACE
 5. TOLERANCES :
 DECIMALS
 .X ±0.3
 .XX ±0.15

ITEM	PART NO.	PART NAME	PRFRM or MTRL	REMARK	QTY
		ALPHA COLTD.			
		MATERIAL NOTE 3, 4			
		SCALE 1:1 (K1)			
		DATE 2002.11.18			
		DSGN & DWG Y.SUZUKI			
		NAME P4 - Xeon Passive Heatlink			
		U6489C-25A			
		PART NO. & DWG NO. S 0 0 1 Z E 0 H			
		DVSN/NO.			
		SPCL			
		SMUR			
		STD			
		MSTD			