

| REVISIONS | | | | |
|-----------|------------|---|-------|-------|
| REV | DATE | DESCRIPTION | CHG | APPR |
| | OCT 03 '13 | CHANGED BEND-SPEC (NOTE.7) OF THE FINS. | Y. S. | Y. S. |

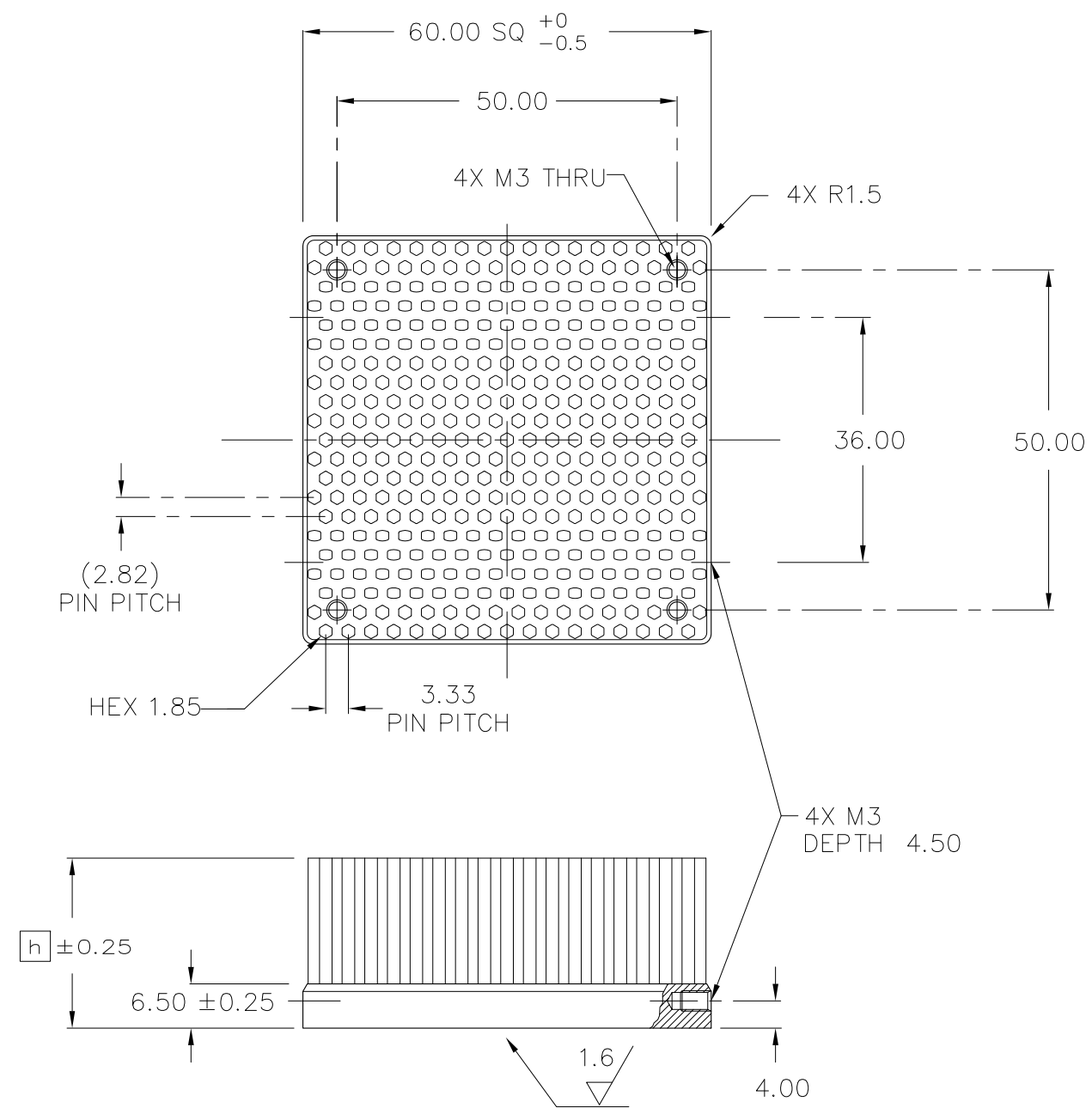

- NOTES : UNLESS OTHERWISE SPECIFIED
1. INTERPRET DIMENSIONS AND TOLERANCES PER ANSI Y14.5M-1982
 2. ALL DIMENSIONS ARE IN MILLIMETERS.
 3. MATERIAL : ALUMINUM 6063
 4. FINISH : CLEAR ANODIZE
 5. TOLERANCES : .XX ±0.254
.XXX ±0.127
ANGLES ± 1°
 6. REMOVE ALL BURRS AND BREAK SHARP EDGES.
 7. A BEND OF THE FIN: THE FINS MUST NOT CONTACT.

| | | | |
|-----------------------|-------------------------|---------------------|--------|
| 30 | FH6030A | S001Z009 | |
| 20 | FH6020A | S001Z006 | |
| HEIGHT h | MODEL NO. | PART NO. | REMARK |
| ALPHA CO.,LTD. | | CSTM'R'S PART NO. | |
| | MATERIAL NOTE 3, 4 | NAME FH60 XXA | |
| SCALE 1 : 1 | APPR & CHCK Y.SUZUKI | DWG NO. S001Z016 | REV |
| DATE DEC 25. '04 | DSGN & DWG Y.SUZUKI | RDCTN: | LOFF: |