

REVISIONS				
REV	DATE	DESCRIPTION	CHG	APPR

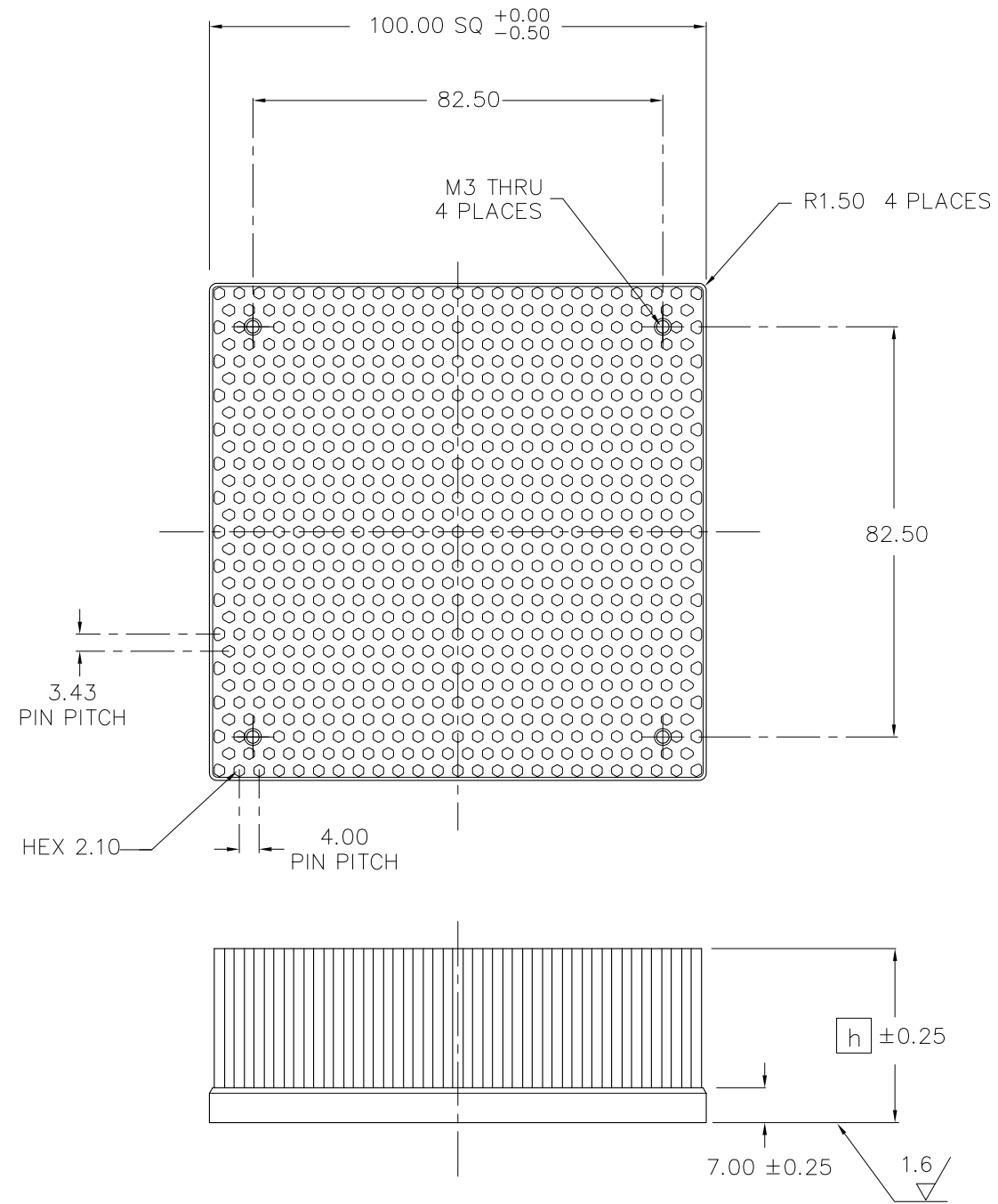

NOTES : UNLESS OTHERWISE SPECIFIED

1. INTERPRET DIMENSIONS AND TOLERANCES PER ANSI Y14.5M
2. ALL DIMENSIONS ARE IN MILLIMETERS.
3. MATERIAL : ALUMINUM 6063
4. FINISH : CLEAR ANODIZE
5. TOLERANCES :  

.XX	±0.254
.XXX	±0.127
ANGLES	± 1°
6. REMOVE ALL BURRS AND BREAK SHARP EDGES.  
UNSPECIFIED CORNER R0.5 MAX OR C0.5 MAX
7. A BEND OF THE FIN: THE FINS MUST NOT CONTACT.

40	FH10040W	S001Z01N	
25	FH10025W	S001Z01M	
HEIGHT h	MODEL NO.	PART NUMBER	REMARK

<b>ALPHA CO.,LTD.</b>		CSTM'R'S PART NO.	
	MATERIAL NOTE 3, 4	NAME FH100 XXW	
SCALE 1 : 1	APPR & CHCK Y.SUZUKI	PART NO. & DWG NO.	REV
DATE APR 17 2014	DSGN & DWG Y.SUZUKI	S001Z01L	
		RDCTN:	LOFF: