

UBR Series

Low Pressure Drop and
Low Thermal Resistance Heat Sink
with Mounting Tabs

ALPHA

ALPHA

Low Pressure Drop and
Low Thermal Resistance Heat Sink
with Mounting Tabs

UBR25

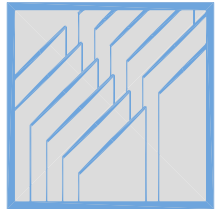

DIM

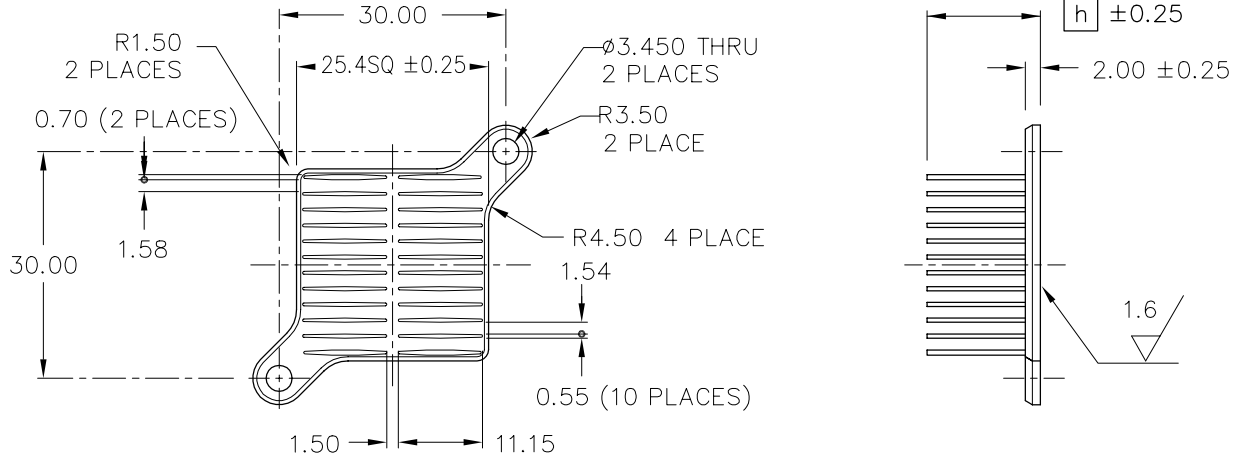

| MODEL | HEIGHT h | WEIGHT (grams) |
|-----------|------------|----------------|
| UBR25-10B | 10 | 6.7 |
| UBR25-15B | 15 | 8.5 |
| UBR25-20B | 20 | 10.3 |

MATERIAL : A 6063
FINISH : BLACK ANODIZE
DIMENSIONS : mm

DATA

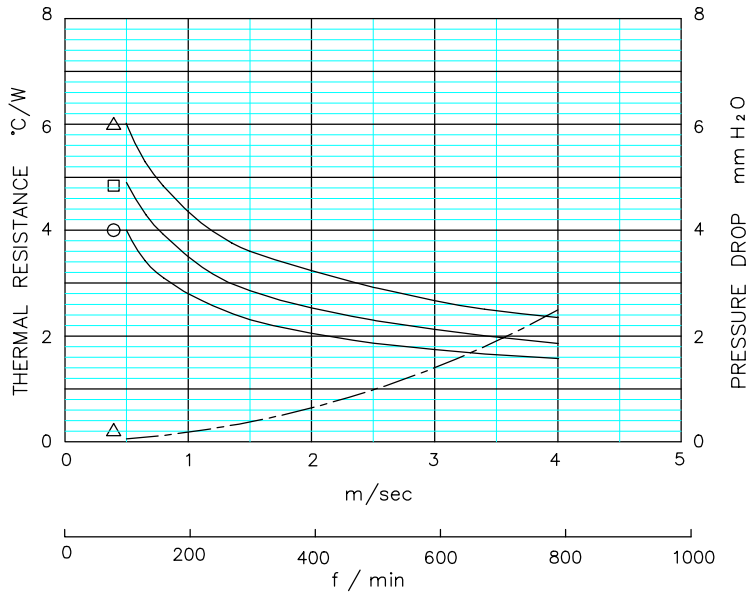

△ UBR25-10B
□ UBR25-15B
○ UBR25-20B

● Thermal Resistance (Ducted)
(Solid Line ———)
● Pressure Drop
(Center Line - - - -)

■ Based on Alpha's Standard Test Procedure. (Refer to page marked Technical Information.)
Dummy Heater Size: 12.7SQ

Alpha Company Ltd.

256-1 UEDA, NUMAZU-CITY SHIZUOKA-PREF., JAPAN
PHONE +81(55)966 0789
FAX +81(55)966 9192
E mail : alpha@micforg.co.jp
URL : <http://www.micforg.co.jp>

Alpha Novatech, Inc. - a subsidiary of Alpha Company.

473 Sapena Ct. #12 Santa Clara, CA 95054 USA
PHONE +1(408)567-8082
FAX +1(408)567-8053
E mail : sales@alphanovatech.com
URL : <http://www.alphanovatech.com>

ALPHA

Low Pressure Drop and
Low Thermal Resistance Heat Sink
with Mounting Tabs

UBR30

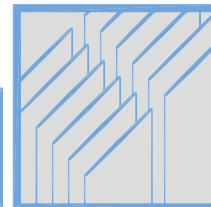

DIM

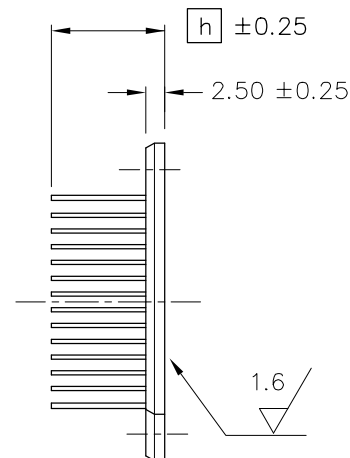
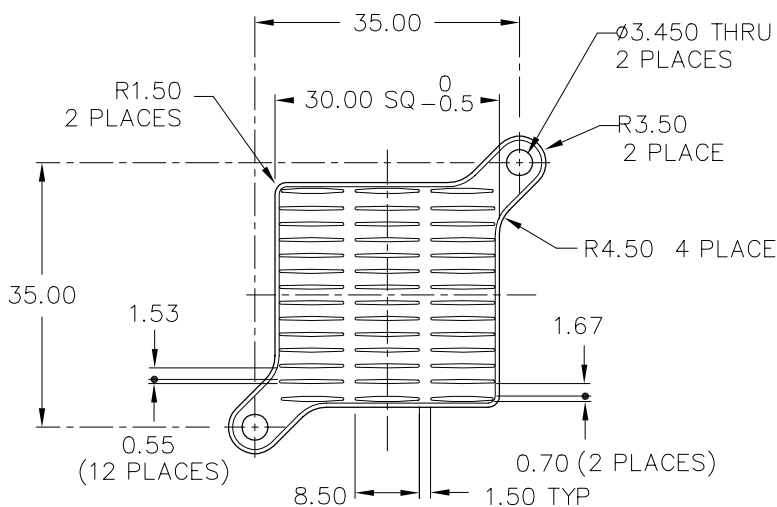

| MODEL | HEIGHT [h] | WEIGHT (grams) |
|-----------|------------|----------------|
| UBR30-10B | 10 | 10.0 |
| UBR30-15B | 15 | 12.4 |
| UBR30-20B | 20 | 14.8 |

MATERIAL : A 6063
FINISH : BLACK ANODIZE
DIMENSIONS : mm

DATA

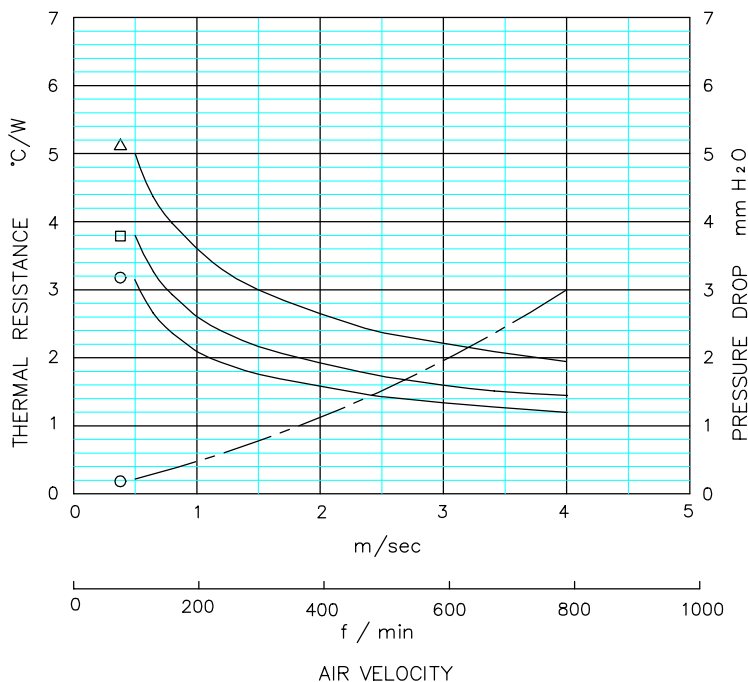

- △ UBR30-10B
- UBR30-15B
- UBR30-20B
- Thermal Resistance (Ducted)
(Solid Line ———)
- Pressure Drop
(Center Line - - -)

■ Based on Alpha's Standard Test Procedure. (Refer to page marked Technical Information.)
Dummy Heater Size : 12.7SQ

Alpha Company Ltd.

256-1 UEDA, NUMAZU-CITY SHIZUOKA-PREF., JAPAN
PHONE +81(55)966 0789
FAX +81(55)966 9192
E mail : alpha@micforg.co.jp
URL : http://www.micforg.co.jp

Alpha Novatech, Inc. - a subsidiary of Alpha Company.

473 Sapena Ct. #12 Santa Clara, CA 95054 USA
PHONE +1(408)567-8082
FAX +1(408)567-8053
E mail : sales@alphanovatech.com
URL : http://www.alphanovatech.com

ALPHA

Low Pressure Drop and
Low Thermal Resistance Heat Sink
with Mounting Tabs

UBR35

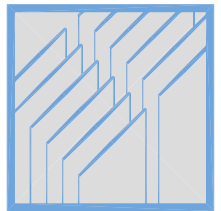

DIM

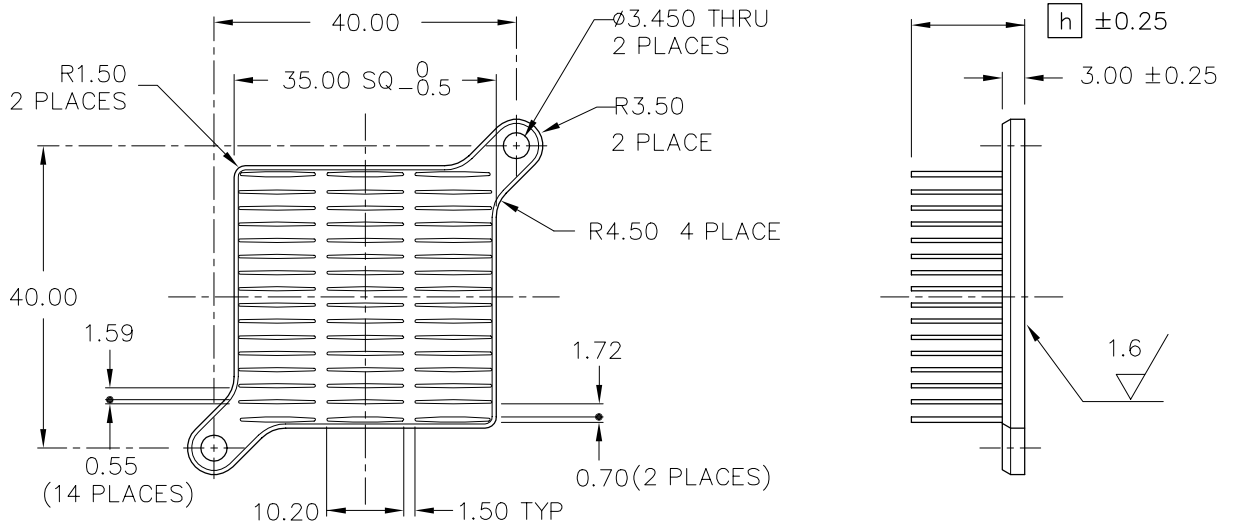

| MODEL | HEIGHT h | WEIGHT (grams) |
|-----------|------------|----------------|
| UBR35-10B | 10 | 14.9 |
| UBR35-15B | 15 | 18.1 |
| UBR35-20B | 20 | 21.3 |

MATERIAL : A 6063
FINISH : BLACK ANODIZE
DIMENSIONS : mm

DATA

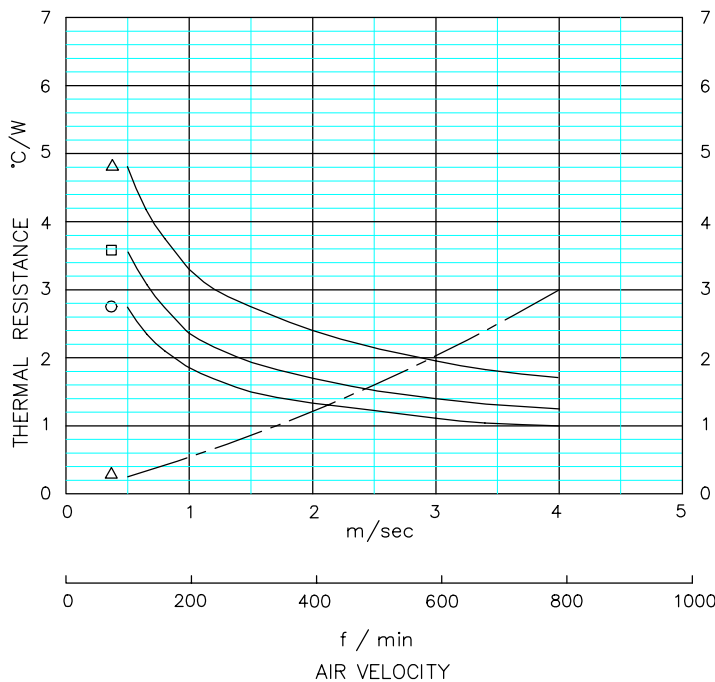

△ UBR35-10B
□ UBR35-15B
○ UBR35-20B

● Thermal Resistance (Ducted)
(Solid Line ———)
● Pressure Drop
(Center Line - - - -)

■ Based on Alpha's Standard Test Procedure. (Refer to page marked Technical Information.)
Dummy Heater Size : 12.75SQ

Alpha Company Ltd.

256-1 UEDA, NUMAZU-CITY SHIZUOKA-PREF., JAPAN
PHONE +81(55)966 0789
FAX +81(55)966 9192
E mail : alpha@micforg.co.jp
URL : <http://www.micforg.co.jp>

Alpha Novatech, Inc. - a subsidiary of Alpha Company.

473 Sapena Ct. #12 Santa Clara, CA 95054 USA
PHONE +1(408)567-8082
FAX +1(408)567-8053
E mail : sales@alphanovatech.com
URL : <http://www.alphanovatech.com>

REF



BOARD KEEPOUT PATTERNS FOR LPDR25, UBR25 AND NR25

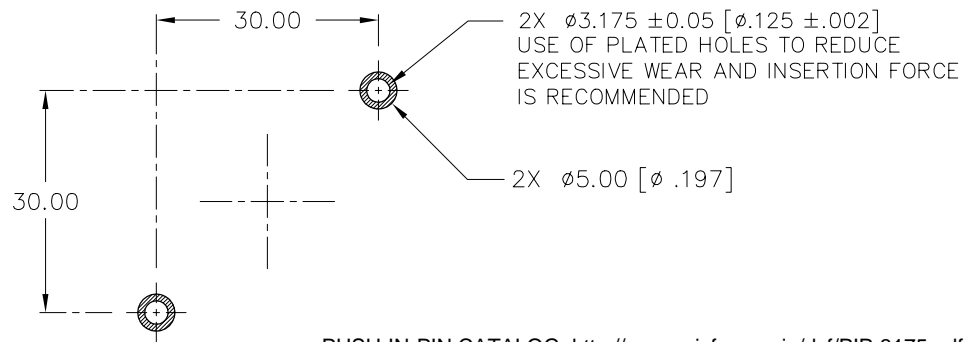

PUSH-IN-PIN CATALOG: <http://www.micforg.co.jp/dxf/PIP-3175.pdf>

BOARD KEEPOUT PATTERNS FOR LPDR30, UBR30 AND NR30

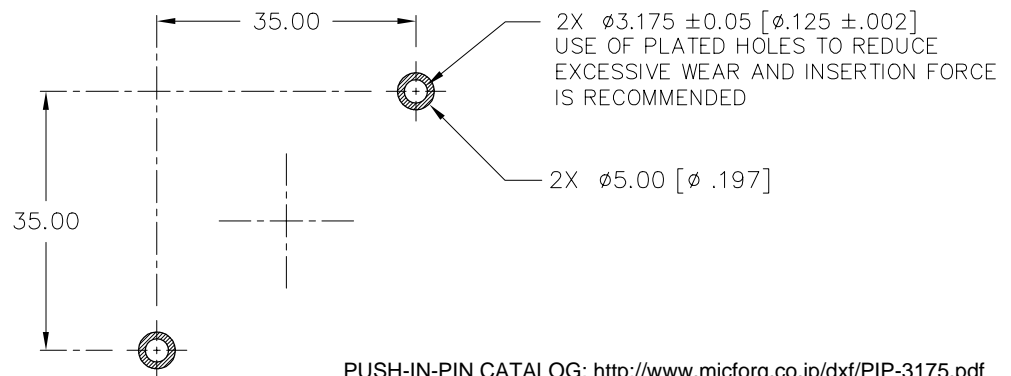

PUSH-IN-PIN CATALOG: <http://www.micforg.co.jp/dxf/PIP-3175.pdf>

BOARD KEEPOUT PATTERNS FOR LPDR35, UBR35 AND NR35

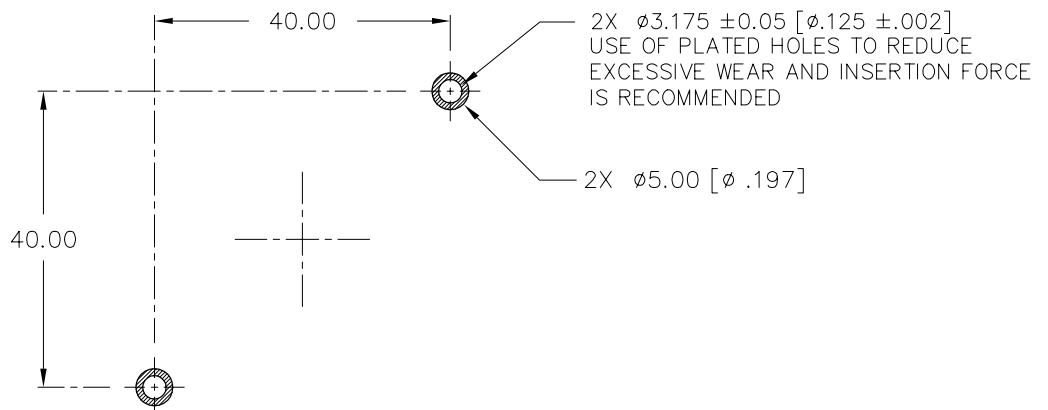

PUSH-IN-PIN CATALOG: <http://www.micforg.co.jp/dxf/PIP-3175.pdf>