

# ZM Series ZH Series

Ultra-High Performance Heat Sink  
with Attachment Holes

**ALPHA**

# ALPHA

## Ultra-High Performance Heat Sink with attachment holes

# ZM25

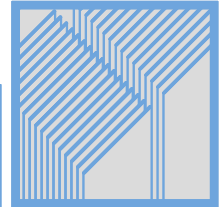

DIM



ZM25-XXBC  
FOR  $\phi 2.500 \pm 0.05$  PCB HOLES

ZM25-XXBP  
FOR  $\phi 3.175 \pm 0.05$  PCB HOLES

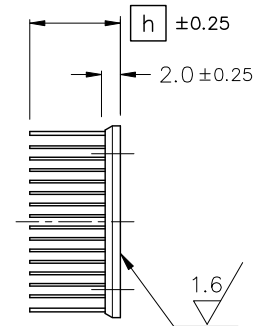
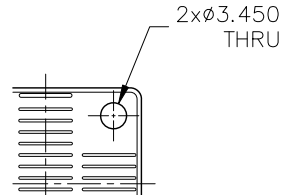
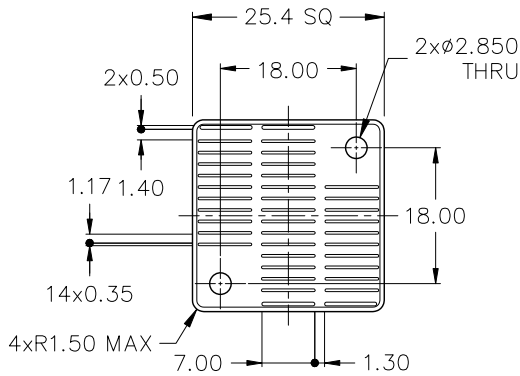

FOR  $\phi 2.500 \pm 0.05$  PCB HOLES

MODEL	HEIGHT $h$	WEIGHT(g)
ZM25-8BC	8	4.9
ZM25-9.5BC	9.5	5.3
ZM25-12.7BC	12.7	6.1

FOR  $\phi 3.175 \pm 0.05$  PCB HOLES

MODEL	HEIGHT $h$	WEIGHT(g)
ZM25-8BP	8	4.9
ZM25-9.5BP	9.5	5.3
ZM25-12.7BP	12.7	6.1

MATERIAL : A 6063  
FINISH : BLACK ANODIZE  
DIMENSIONS : mm

DATA

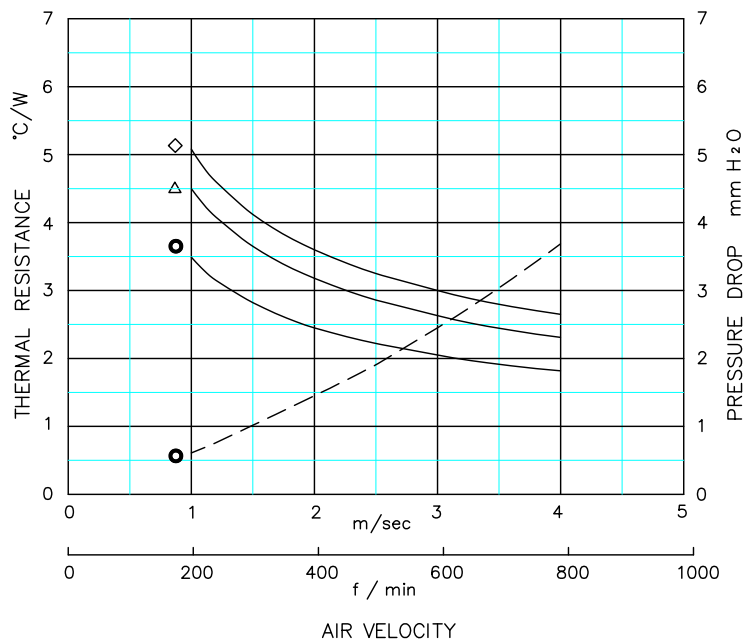

- ◇ ZM25-8BC, ZM25-8BP
- △ ZM25-9.5BC, ZM25-9.5BP
- ZM25-12.7BC, ZM25-12.7BP

- DUCTED CONDITION  
DUMMY HEATER SIZE: 12.7 SQ  
THERMAL RESISTANCE ————  
PRESURE DROP - - - - -

- BASED ON ALPHA'S STANDARD TEST PROCEDURE.  
REFER TO TECHNICAL INFORMATION.

Alpha Company Ltd.

256-1 UEDA, NUMAZU-CITY SHIZUOKA-PREF., JAPAN  
PHONE +81(55)966 0789  
FAX +81(55)966 9192  
E mail : alpha@micforg.co.jp  
URL : <https://www.micforg.co.jp>

Alpha Novatech, Inc. - a subsidiary of Alpha Company.

473 Sapena Ct. #12 Santa Clara, CA 95054 USA  
PHONE +1(408)567-8082  
FAX +1(408)567-8053  
E mail : sales@alphanovatech.com  
URL : <https://www.alphanovatech.com>

# ALPHA

Ultra-High Performance Heat Sink  
with attachment holes

# ZM30

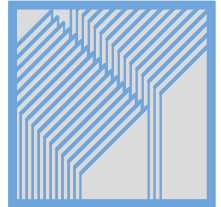

DIM

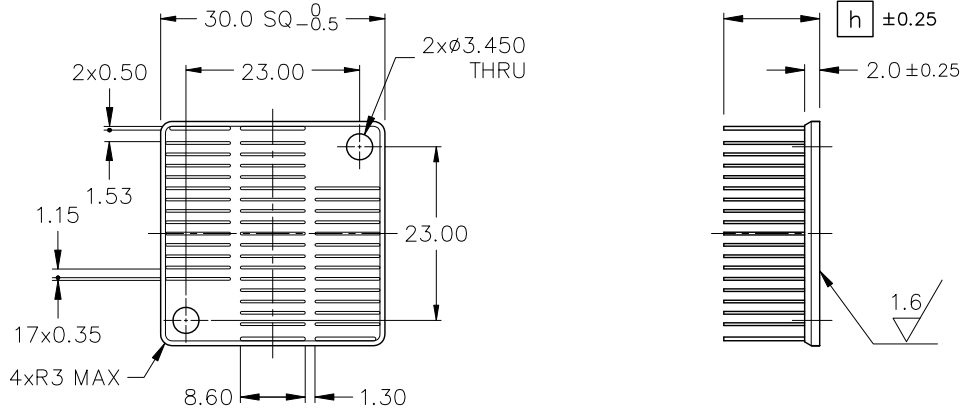

MODEL	HEIGHT $h$	WEIGHT(g)
ZM30-8BP	8.0	6.8
ZM30-9.5BP	9.5	7.4
ZM30-12.7BP	12.7	8.6

MATERIAL : A 6063  
FINISH : BLACK ANODIZE  
DIMENSIONS : mm

DATA

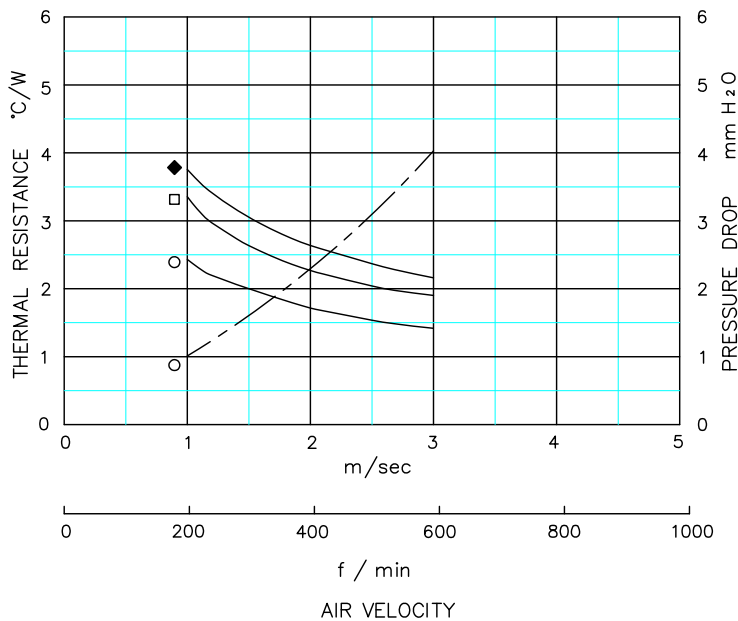

- ◆ ZM30-8BP
- ZM30-9.5BP
- ZM30-12.7BP

- DUCTED CONDITION  
DUMMY HEATER SIZE: 12.7 SQ
- THERMAL RESISTANCE
- - - PRESSURE DROP

■ BASED ON ALPHA'S STANDARD TEST PROCEDURE.  
REFER TO TECHNICAL INFORMATION.

Alpha Company Ltd.

256-1 UEDA, NUMAZU-CITY SHIZUOKA-PREF., JAPAN  
PHONE +81(55)966 0789  
FAX +81(55)966 9192  
E mail : alpha@micforg.co.jp  
URL : <https://www.micforg.co.jp>

Alpha Novatech, Inc. - a subsidiary of Alpha Company.

473 Sapena Ct. #12 Santa Clara, CA 95054 USA  
PHONE +1(408)567-8082  
FAX +1(408)567-8053  
E mail : sales@alphanovatech.com  
URL : <https://www.alphanovatech.com>

# ALPHA

## Ultra-High Performance Heat Sink with attachment holes

# ZM35

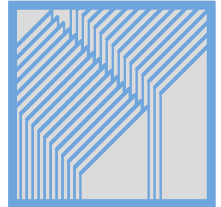

DIM

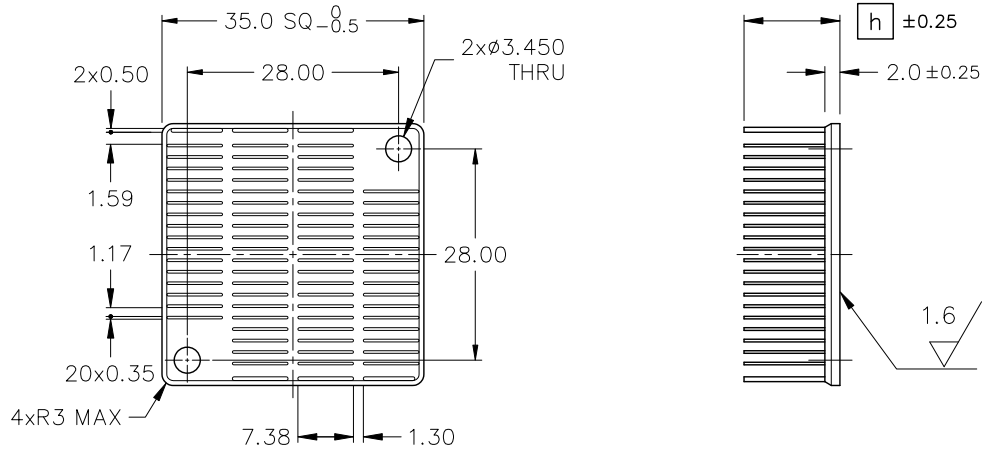

MODEL	HEIGHT [h]	WEIGHT(g)
ZM35-8BP	8.0	6.8
ZM35-9.5BP	9.5	7.4
ZM35-12.7BP	12.7	8.6

MATERIAL : A 6063  
 FINISH : BLACK ANODIZE  
 DIMENSIONS : mm

DATA

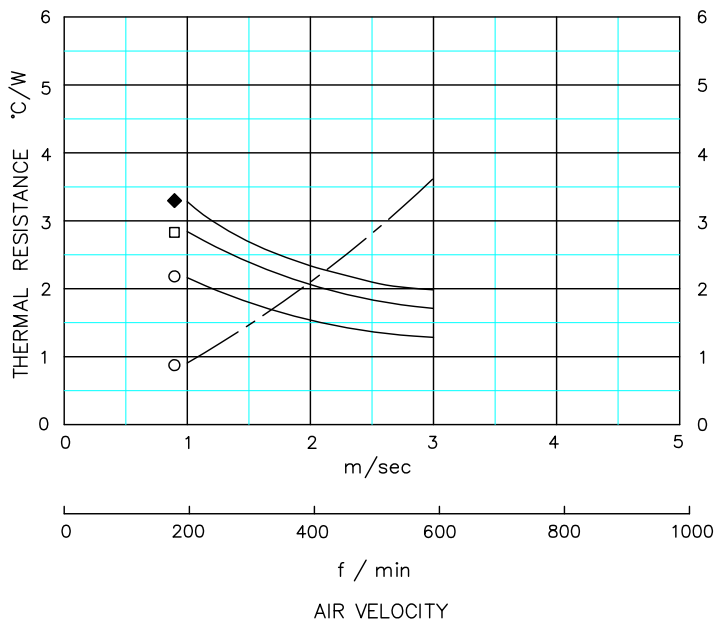

- ◆ ZM35-8BP
- ZM35-9.5BP
- ZM35-12.7BP

- DUCTED CONDITION  
 DUMMY HEATER SIZE: 12.7 SQ  
 THERMAL RESISTANCE ———  
 PRESURE DROP - - - - -

■ BASED ON ALPHA'S STANDARD TEST PROCEDURE.  
 REFER TO TECHNICAL INFORMATION.

Alpha Company Ltd.

256-1 UEDA, NUMAZU-CITY SHIZUOKA-PREF., JAPAN  
 PHONE +81(55)966 0789  
 FAX +81(55)966 9192  
 E mail : alpha@micforg.co.jp  
 URL : <https://www.micforg.co.jp>

Alpha Novatech, Inc. - a subsidiary of Alpha Company.

473 Sapena Ct. #12 Santa Clara, CA 95054 USA  
 PHONE +1(408)567-8082  
 FAX +1(408)567-8053  
 E mail : sales@alphanovatech.com  
 URL : <https://www.alphanovatech.com>

# ALPHA

## Ultra-High Performance Heat Sink with attachment holes

# ZM40

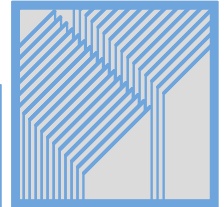

DIM

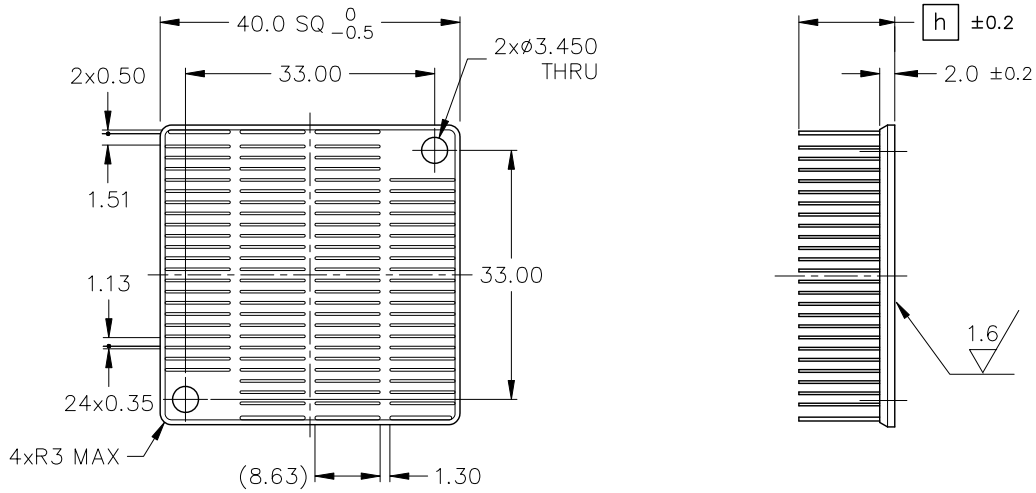

MODEL	HEIGHT [h]	WEIGHT(g)
ZM40-9.5BP	9.5	14.9
ZM40-12.7BP	12.7	17.6

MATERIAL : A 6063  
 FINISH : BLACK ANODIZE  
 DIMENSIONS : mm

DATA

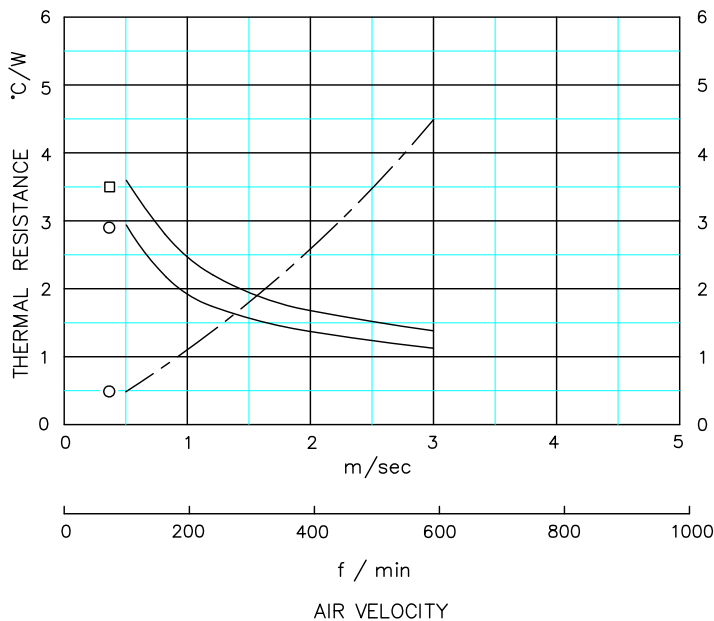

□ ZM40-9.5BP  
 ○ ZM40-12.7BP

● DUCTED CONDITION  
 DUMMY HEATER SIZE: 12.7 SQ  
 THERMAL RESISTANCE ———  
 PRESURE DROP - - - - -

■ BASED ON ALPHA'S STANDARD TEST PROCEDURE.  
 REFER TO TECHNICAL INFORMATION.

Alpha Company Ltd.

256-1 UEDA, NUMAZU-CITY SHIZUOKA-PREF., JAPAN  
 PHONE +81(55)966 0789  
 FAX +81(55)966 9192  
 E mail : alpha@micforg.co.jp  
 URL : <https://www.micforg.co.jp>

Alpha Novatech, Inc. - a subsidiary of Alpha Company.

473 Sapena Ct. #12 Santa Clara, CA 95054 USA  
 PHONE +1(408)567-8082  
 FAX +1(408)567-8053  
 E mail : sales@alphanovatech.com  
 URL : <https://www.alphanovatech.com>

# ALPHA

## Ultra-High Performance Heat Sink ZM45 with attachment holes

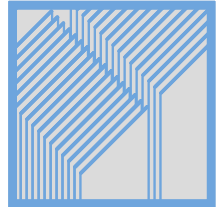

DIM

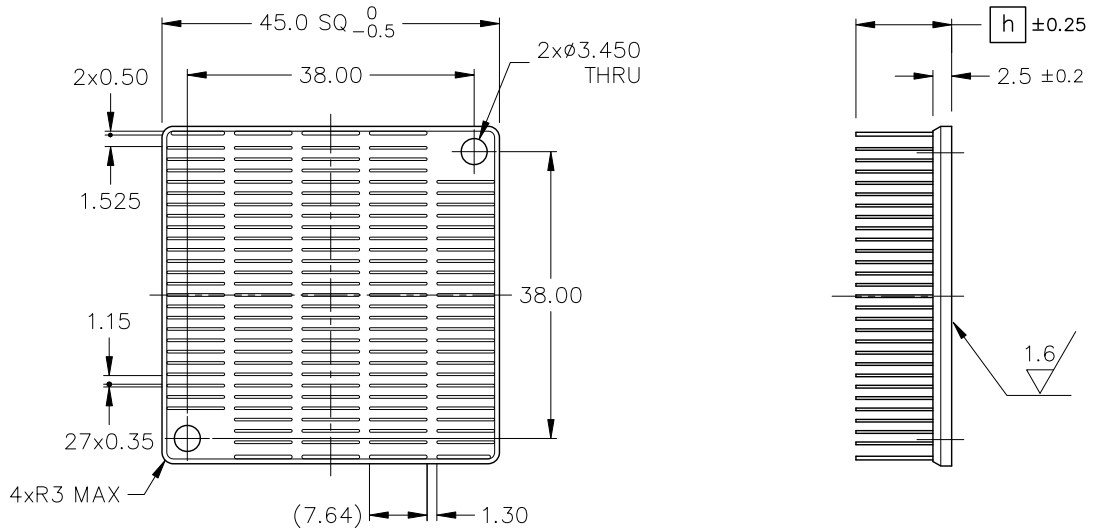

MODEL	HEIGHT [h]	WEIGHT(g)
ZM45-9.5BP	9.5	20.9
ZM45-12.7BP	12.7	24.7

MATERIAL : A 6063  
FINISH : BLACK ANODIZE  
DIMENSIONS : mm

DATA

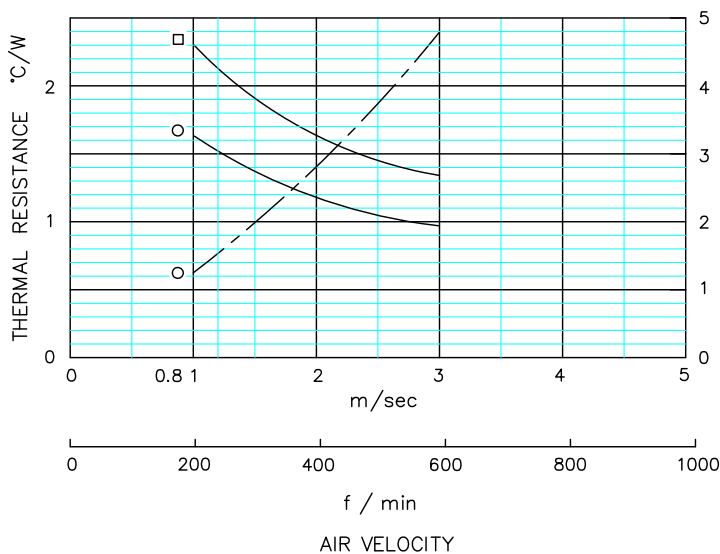

□ ZM45-9.5BP  
○ ZM45-12.7BP

● DUCTED CONDITION  
DUMMY HEATER SIZE: 12.7 SQ  
THERMAL RESISTANCE ———  
PRESURE DROP - - - - -

■ BASED ON ALPHA'S STANDARD TEST PROCEDURE.  
REFER TO TECHNICAL INFORMATION.

Alpha Company Ltd.

256-1 UEDA, NUMAZU-CITY SHIZUOKA-PREF., JAPAN  
PHONE +81(55)966 0789  
FAX +81(55)966 9192  
E mail : alpha@micforg.co.jp  
URL : <https://www.micforg.co.jp>

Alpha Novatech, Inc. - a subsidiary of Alpha Company.

473 Sapena Ct. #12 Santa Clara, CA 95054 USA  
PHONE +1(408)567-8082  
FAX +1(408)567-8053  
E mail : sales@alphanovatech.com  
URL : <https://www.alphanovatech.com>

# ALPHA

## Ultra-High Performance Heat Sink ZM50 with attachment holes

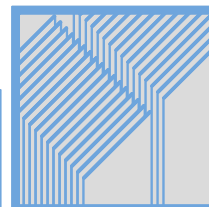

DIM

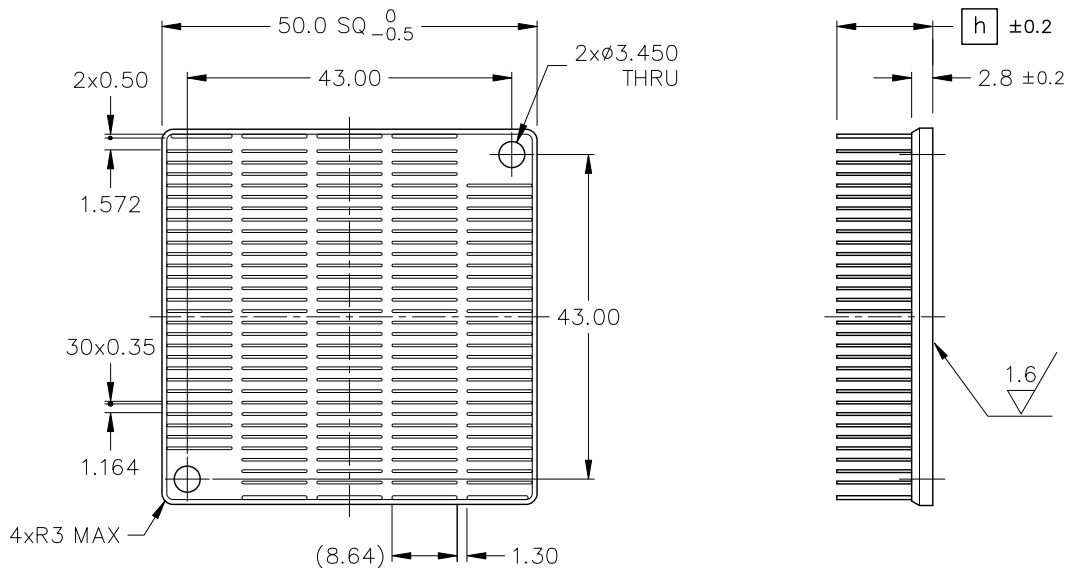

MODEL	HEIGHT $h$	WEIGHT(g)
ZM50-9.5BP	9.5	26.4
ZM50-12.7BP	12.7	30.7

MATERIAL : A 6063  
FINISH : BLACK ANODIZE  
DIMENSIONS : mm

DATA

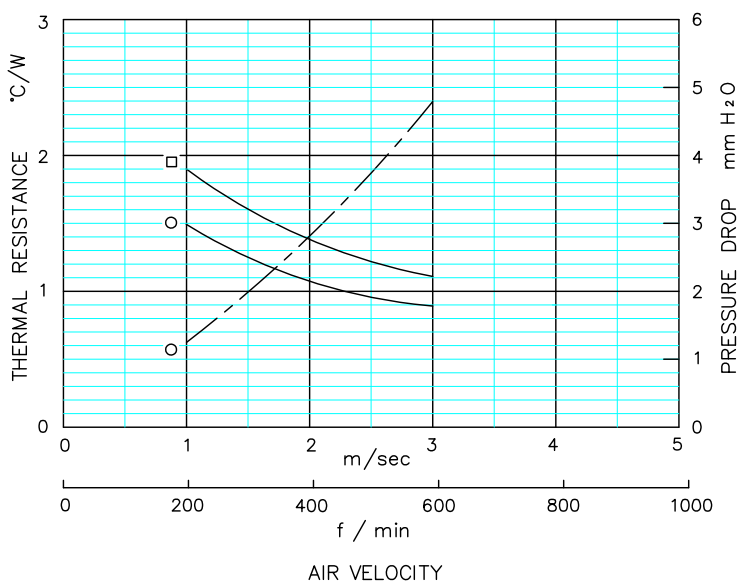

□ ZM50-9.5BP  
○ ZM50-12.7BP

● DUCTED CONDITION  
DUMMY HEATER SIZE: 12.7 SQ  
THERMAL RESISTANCE ———  
PRESURE DROP - - - - -

■ BASED ON ALPHA'S STANDARD TEST PROCEDURE.  
REFER TO TECHNICAL INFORMATION.

Alpha Company Ltd.

256-1 UEDA, NUMAZU-CITY SHIZUOKA-PREF., JAPAN  
PHONE +81(55)966 0789  
FAX +81(55)966 9192  
E mail : alpha@micforg.co.jp  
URL : <https://www.micforg.co.jp>

Alpha Novatech, Inc. - a subsidiary of Alpha Company.

473 Sapena Ct. #12 Santa Clara, CA 95054 USA  
PHONE +1(408)567-8082  
FAX +1(408)567-8053  
E mail : sales@alphanovatech.com  
URL : <https://www.alphanovatech.com>

# ALPHA

## Ultra-High Performance Heat Sink ZM54 with attachment holes

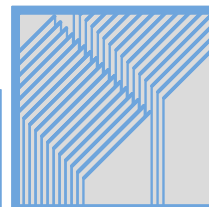

DIM

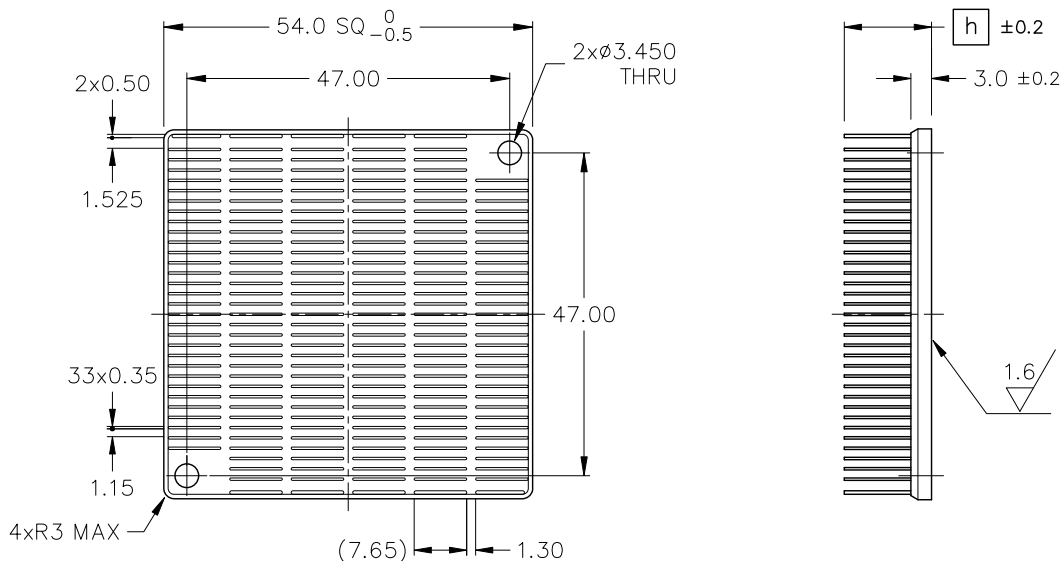

MODEL	HEIGHT [h]	WEIGHT(g)
ZM54-9.5BP	9.5	32.4
ZM54-12.7BP	12.7	37.2

MATERIAL : A 6063  
 FINISH : BLACK ANODIZE  
 DIMENSIONS : mm

DATA

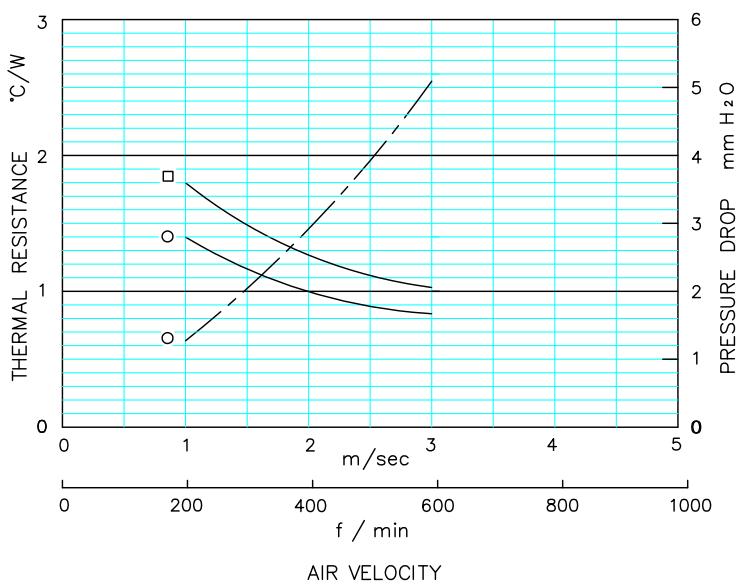

Alpha Company Ltd.

256-1 UEDA, NUMAZU-CITY SHIZUOKA-PREF., JAPAN  
 PHONE +81(55)966 0789  
 FAX +81(55)966 9192  
 E mail : alpha@micforg.co.jp  
 URL : https://www.micforg.co.jp

Alpha Novatech, Inc. - a subsidiary of Alpha Company.

473 Sapena Ct. #12 Santa Clara, CA 95054 USA  
 PHONE +1(408)567-8082  
 FAX +1(408)567-8053  
 E mail : sales@alphanovatech.com  
 URL : https://www.alphanovatech.com



# ALPHA

## Ultra-High Performance Heat Sink with attachment holes

# ZM60

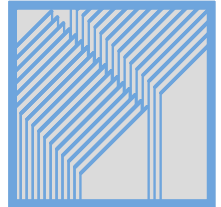

DIM

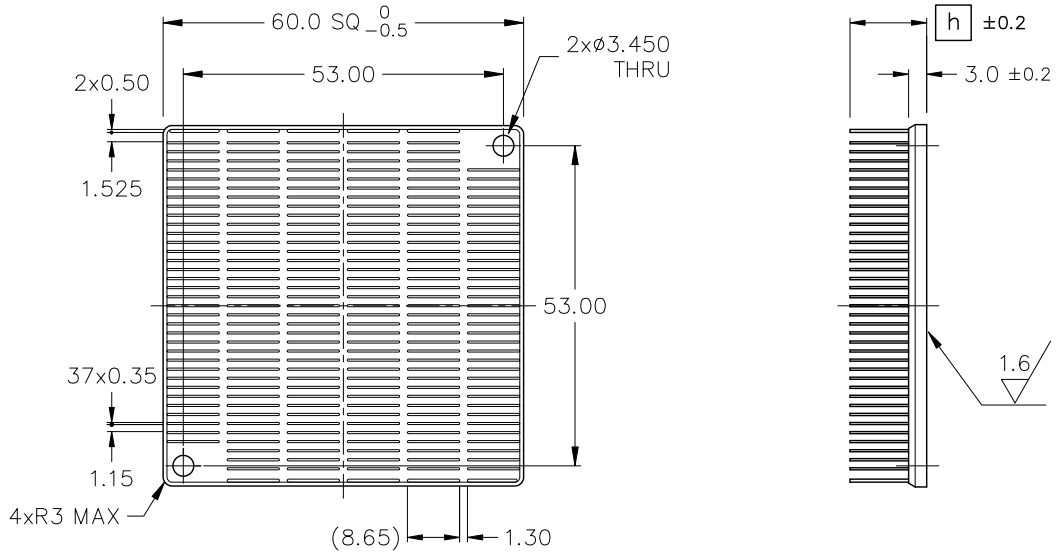

MODEL	HEIGHT [h]	WEIGHT(g)
ZM60-9.5BP	9.5	40.9
ZM60-12.7BP	12.7	46.7

MATERIAL : A 6063  
 FINISH : BLACK ANODIZE  
 DIMENSIONS : mm

DATA

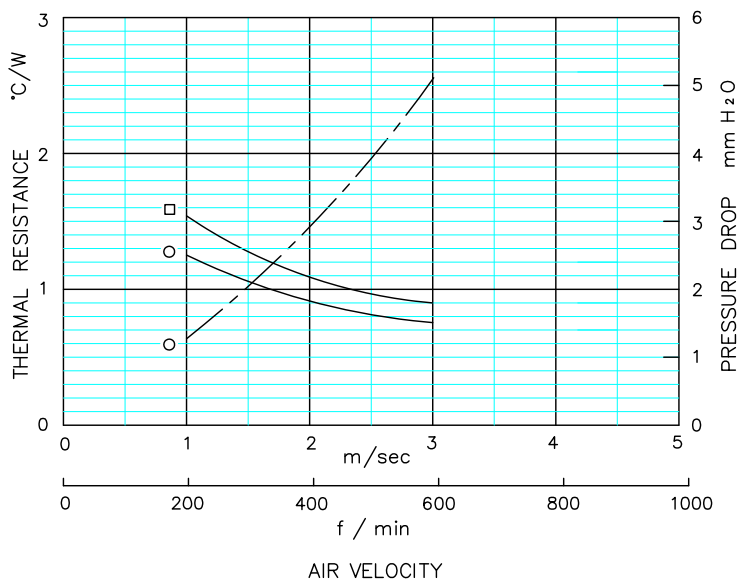

Alpha Company Ltd.

256-1 UEDA, NUMAZU-CITY SHIZUOKA-PREF., JAPAN  
 PHONE +81(55)966 0789  
 FAX +81(55)966 9192  
 E mail : alpha@micforg.co.jp  
 URL : <https://www.micforg.co.jp>

Alpha Novatech, Inc. - a subsidiary of Alpha Company.

473 Sapena Ct. #12 Santa Clara, CA 95054 USA  
 PHONE +1(408)567-8082  
 FAX +1(408)567-8053  
 E mail : sales@alphanovatech.com  
 URL : <https://www.alphanovatech.com>

REF



## PCB HOLE LAYOUT

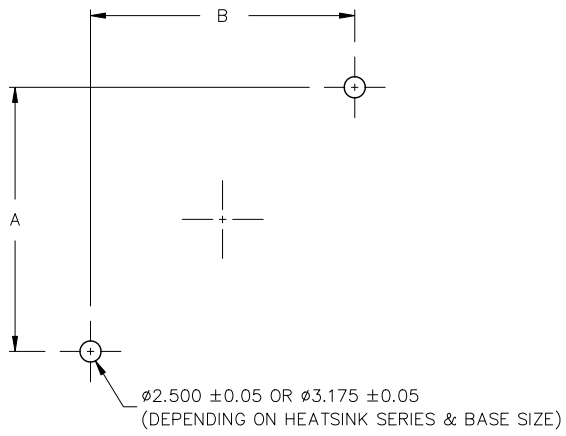

LPDM25, UBM25, ZM25	18.0	18.0
LPDM30, UBM30, ZM30	23.0	23.0
LPDM35, UBM35, ZM35	28.0	28.0
LPDM40, UBM40, ZM40	33.0	33.0
LPDM45, UBM45, ZM45	38.0	38.0
LPDM50, UBM50, ZM50, FFM50	43.0	43.0
LPDM54, UBM54, ZM54, FFM54	47.0	47.0
LPDM60, UBM60, ZM60	53.0	53.0
LPDM70, UBM70	63.0	63.0
MODEL	A	B

# ALPHA

## Ultra-High Performance Heat Sink with attachment holes

# ZH 25

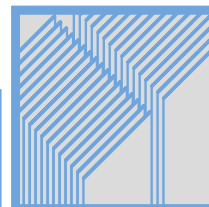

DIM



ZH25-XXBC  
FOR  $\phi 2.500 \pm 0.05$  PCB HOLES

ZH25-XXBP  
FOR  $\phi 3.175 \pm 0.05$  PCB HOLES

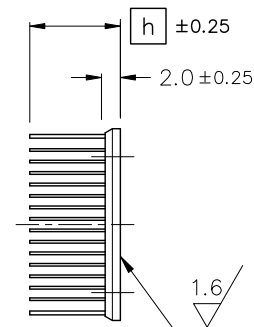
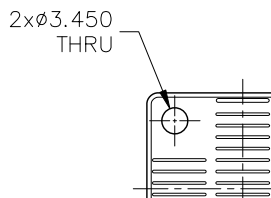
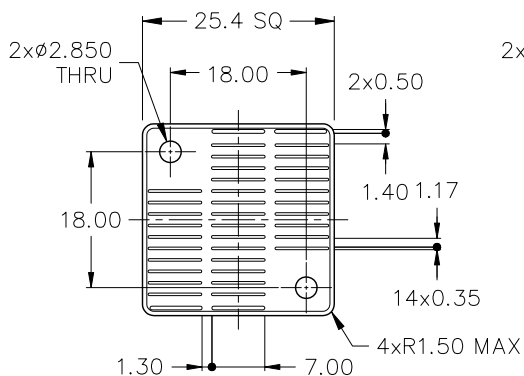

FOR  $\phi 2.500 \pm 0.05$  PCB HOLES

MODEL	HEIGHT $h$	WEIGHT(g)
ZH25-8BC	8	4.9
ZH25-9.5BC	9.5	5.3
ZH25-12.7BC	12.7	6.1

FOR  $\phi 3.175 \pm 0.05$  PCB HOLES

MODEL	HEIGHT $h$	WEIGHT(g)
ZH25-8BP	8	4.9
ZH25-9.5BP	9.5	5.3
ZH25-12.7BP	12.7	6.1

MATERIAL : A 6063  
FINISH : BLACK ANODIZE  
DIMENSIONS : mm

DATA

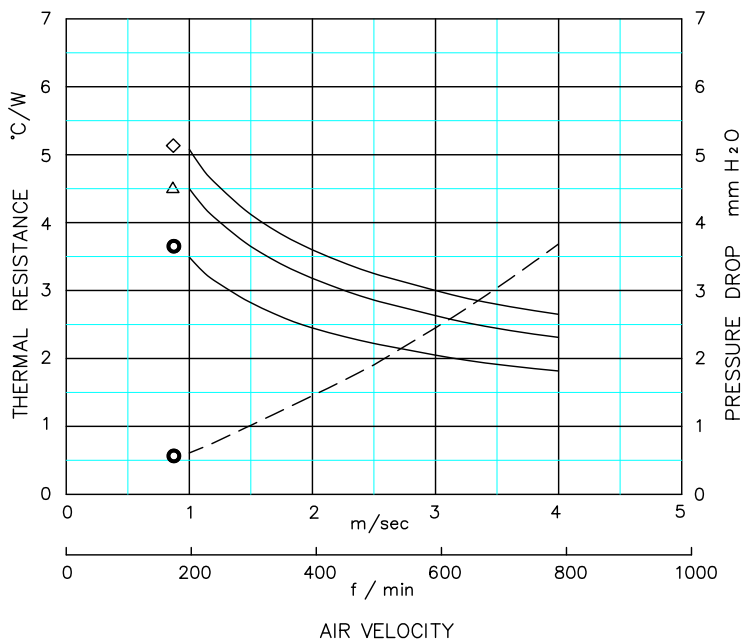

- ◇ ZH25-8BC, ZH25-8BP
- △ ZH25-9.5BC, ZH25-9.5BP
- ZH25-12.7BC, ZH25-12.7BP

- DUCTED CONDITION  
DUMMY HEATER SIZE: 12.7 SQ  
THERMAL RESISTANCE ———  
PRESURE DROP - - - - -

■ BASED ON ALPHA'S STANDARD TEST PROCEDURE.  
REFER TO TECHNICAL INFORMATION.

Alpha Company Ltd.

256-1 UEDA, NUMAZU-CITY SHIZUOKA-PREF., JAPAN  
PHONE +81(55)966 0789  
FAX +81(55)966 9192  
E mail : alpha@micforg.co.jp  
URL : <https://www.micforg.co.jp>

Alpha Novatech, Inc. - a subsidiary of Alpha Company.

473 Sapena Ct. #12 Santa Clara, CA 95054 USA  
PHONE +1(408)567-8082  
FAX +1(408)567-8053  
E mail : sales@alphanovatech.com  
URL : <https://www.alphanovatech.com>

# ALPHA

## Ultra-High Performance Heat Sink with attachment holes

# ZH30

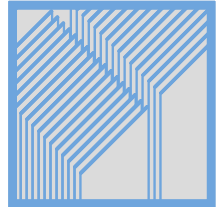

DIM

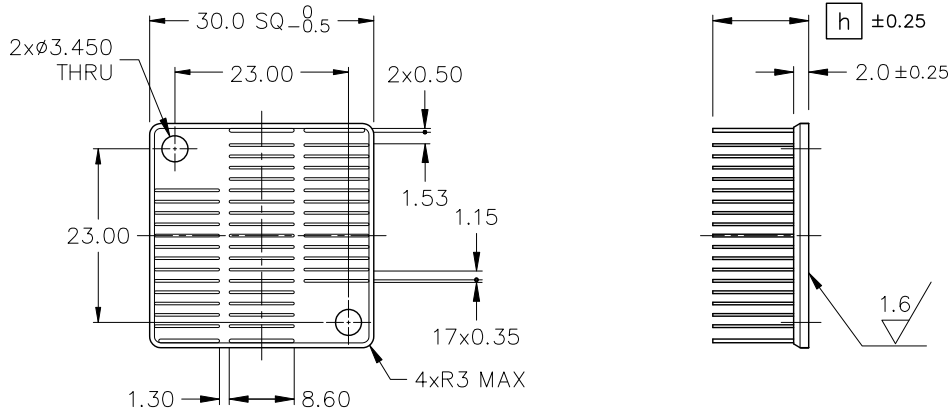

MODEL	HEIGHT [h]	WEIGHT(g)
ZH30-8BP	8.0	6.8
ZH30-9.5BP	9.5	7.4
ZH30-12.7BP	12.7	8.6

MATERIAL : A 6063  
 FINISH : BLACK ANODIZE  
 DIMENSIONS : mm

DATA

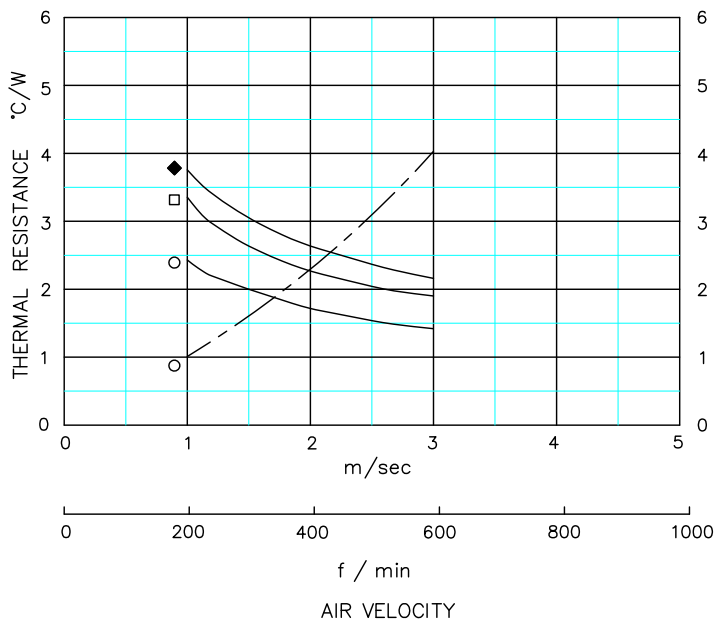

- ◆ ZH30-8BP
- ZH30-9.5BP
- ZH30-12.7BP

- DUCTED CONDITION
- DUMMY HEATER SIZE: 12.7 SQ
- THERMAL RESISTANCE ———
- PRESURE DROP - - - - -

■ BASED ON ALPHA'S STANDARD TEST PROCEDURE.  
 REFER TO TECHNICAL INFORMATION.

Alpha Company Ltd.

256-1 UEDA, NUMAZU-CITY SHIZUOKA-PREF., JAPAN  
 PHONE +81(55)966 0789  
 FAX +81(55)966 9192  
 E mail : alpha@micforg.co.jp  
 URL : <https://www.micforg.co.jp>

Alpha Novatech, Inc. - a subsidiary of Alpha Company.

473 Sapena Ct. #12 Santa Clara, CA 95054 USA  
 PHONE +1(408)567-8082  
 FAX +1(408)567-8053  
 E mail : sales@alphanovatech.com  
 URL : <https://www.alphanovatech.com>

# ALPHA

## Ultra-High Performance Heat Sink with attachment holes

# ZH35

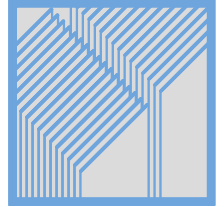

### DIM

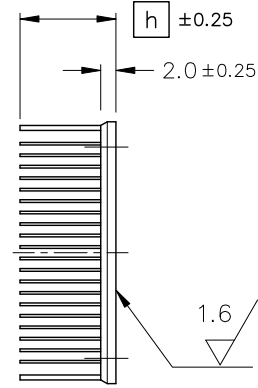
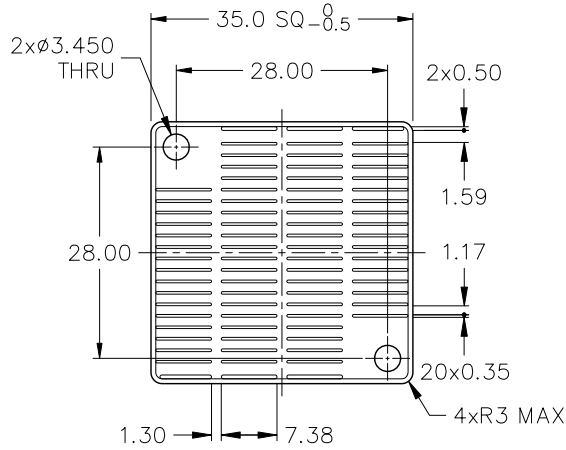

MODEL	HEIGHT [h]	WEIGHT(g)
ZH35-8BP	8.0	6.8
ZH35-9.5BP	9.5	7.4
ZH35-12.7BP	12.7	8.6

MATERIAL : A 6063  
 FINISH : BLACK ANODIZE  
 DIMENSIONS : mm

### DATA

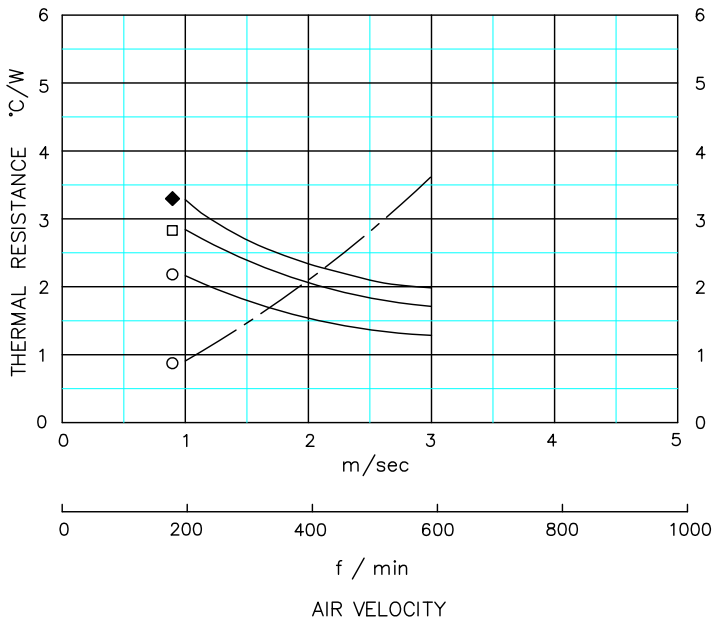

- ◆ ZH35-8BP
- ZH35-9.5BP
- ZH35-12.7BP

● DUCTED CONDITION  
 DUMMY HEATER SIZE: 12.7 SQ  
 THERMAL RESISTANCE ———  
 PRESURE DROP - - - - -

■ BASED ON ALPHA'S STANDARD TEST PROCEDURE.  
 REFER TO TECHNICAL INFORMATION.

Alpha Company Ltd.

256-1 UEDA, NUMAZU-CITY SHIZUOKA-PREF., JAPAN  
 PHONE +81(55)966 0789  
 FAX +81(55)966 9192  
 E mail : alpha@micforg.co.jp  
 URL : <https://www.micforg.co.jp>

Alpha Novatech, Inc. - a subsidiary of Alpha Company.

473 Sapena Ct. #12 Santa Clara, CA 95054 USA  
 PHONE +1(408)567-8082  
 FAX +1(408)567-8053  
 E mail : sales@alphanovatech.com  
 URL : <https://www.alphanovatech.com>

# ALPHA

## Ultra-High Performance Heat Sink with attachment holes

# ZH 40

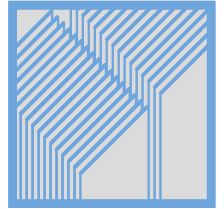

DIM

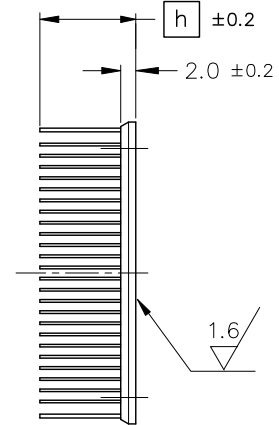
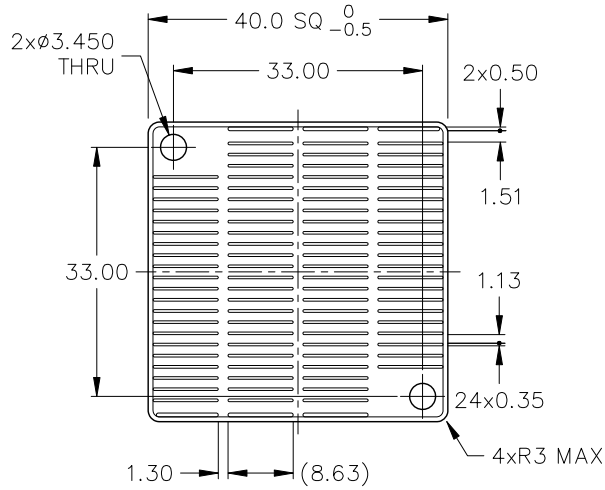

MODEL	HEIGHT [h]	WEIGHT(g)
ZH40-9.5BP	9.5	14.9
ZH40-12.7BP	12.7	17.6

MATERIAL : A 6063  
 FINISH : BLACK ANODIZE  
 DIMENSIONS : mm

DATA

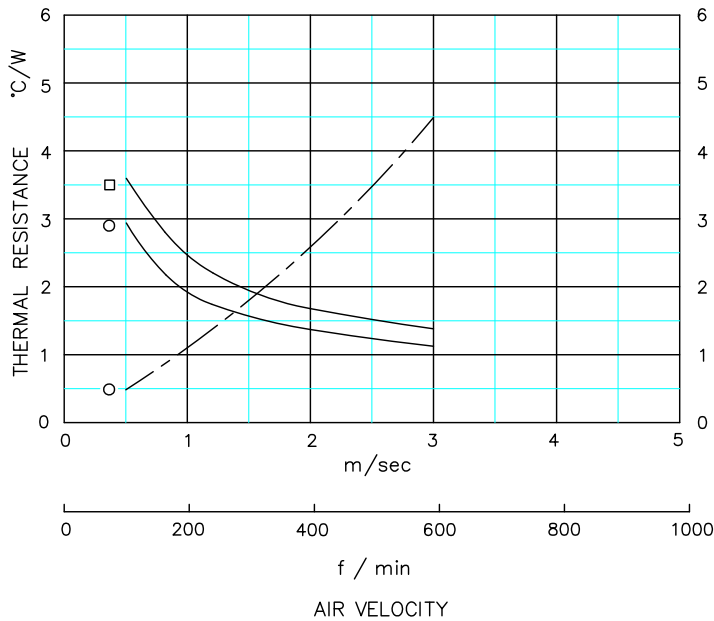

- ZH40-9.5BP
- ZH40-12.7BP

- DUCTED CONDITION  
 DUMMY HEATER SIZE: 12.7 SQ  
 THERMAL RESISTANCE ———  
 PRESURE DROP - - - - -

■ BASED ON ALPHA'S STANDARD TEST PROCEDURE.  
 REFER TO TECHNICAL INFORMATION.

Alpha Company Ltd.

256-1 UEDA, NUMAZU-CITY SHIZUOKA-PREF., JAPAN  
 PHONE +81(55)966 0789  
 FAX +81(55)966 9192  
 E mail : alpha@micforg.co.jp  
 URL : <https://www.micforg.co.jp>

Alpha Novatech, Inc. - a subsidiary of Alpha Company.

473 Sapena Ct. #12 Santa Clara, CA 95054 USA  
 PHONE +1(408)567-8082  
 FAX +1(408)567-8053  
 E mail : sales@alphanovatech.com  
 URL : <https://www.alphanovatech.com>

# ALPHA

## Ultra-High Performance Heat Sink with attachment holes

# ZH 45

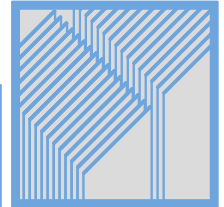

DIM

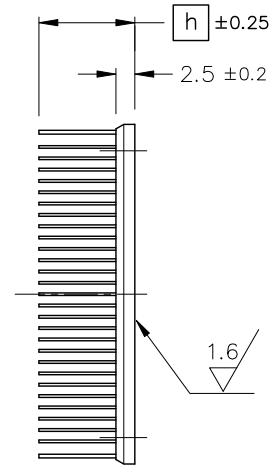
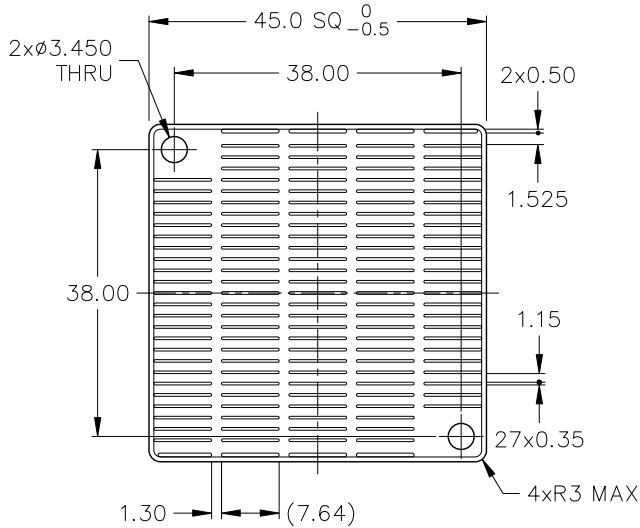

MODEL	HEIGHT [h]	WEIGHT(g)
ZH45-9.5BP	9.5	20.9
ZH45-12.7BP	12.7	24.7

MATERIAL : A 6063  
 FINISH : BLACK ANODIZE  
 DIMENSIONS : mm

DATA

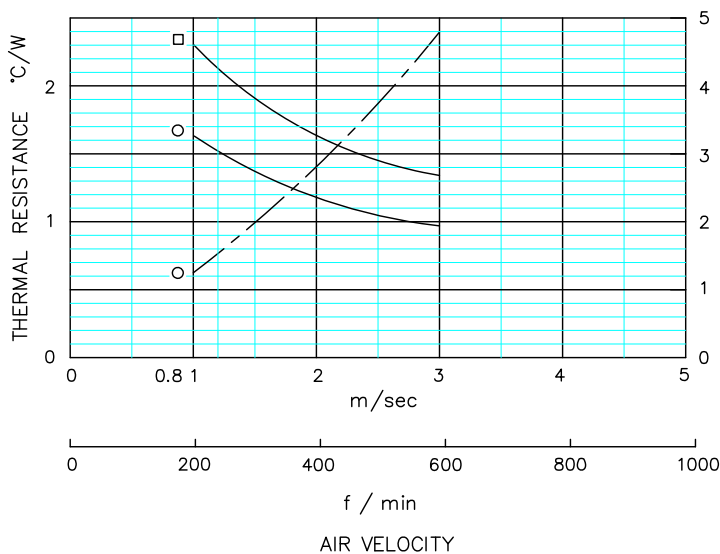

□ ZH45-9.5BP  
 ○ ZH45-12.7BP

● DUCTED CONDITION  
 DUMMY HEATER SIZE: 12.7 SQ  
 THERMAL RESISTANCE ———  
 PRESURE DROP - - - - -

■ BASED ON ALPHA'S STANDARD TEST PROCEDURE.  
 REFER TO TECHNICAL INFORMATION.

Alpha Company Ltd.

256-1 UEDA, NUMAZU-CITY SHIZUOKA-PREF., JAPAN  
 PHONE +81(55)966 0789  
 FAX +81(55)966 9192  
 E mail : alpha@micforg.co.jp  
 URL : <https://www.micforg.co.jp>

Alpha Novatech, Inc. - a subsidiary of Alpha Company.

473 Sapena Ct. #12 Santa Clara, CA 95054 USA  
 PHONE +1(408)567-8082  
 FAX +1(408)567-8053  
 E mail : sales@alphanovatech.com  
 URL : <https://www.alphanovatech.com>

# ALPHA

## Ultra-High Performance Heat Sink with attachment holes

# ZH50

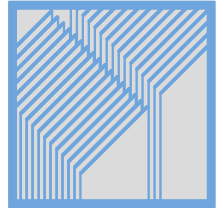

DIM

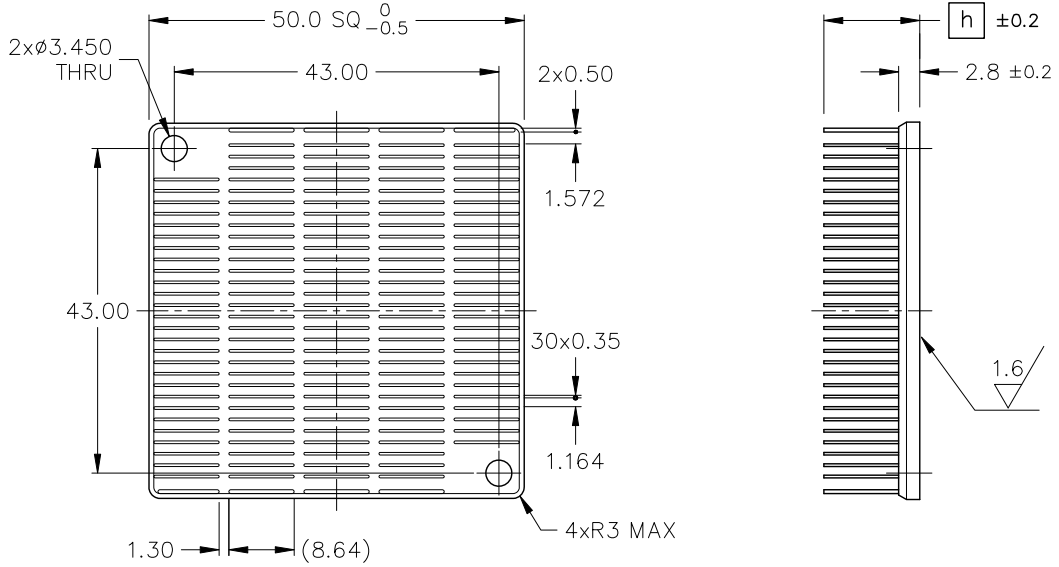

MODEL	HEIGHT $h$	WEIGHT(g)
ZH50-9.5BP	9.5	26.4
ZH50-12.7BP	12.7	30.7

MATERIAL : A 6063  
 FINISH : BLACK ANODIZE  
 DIMENSIONS : mm

DATA

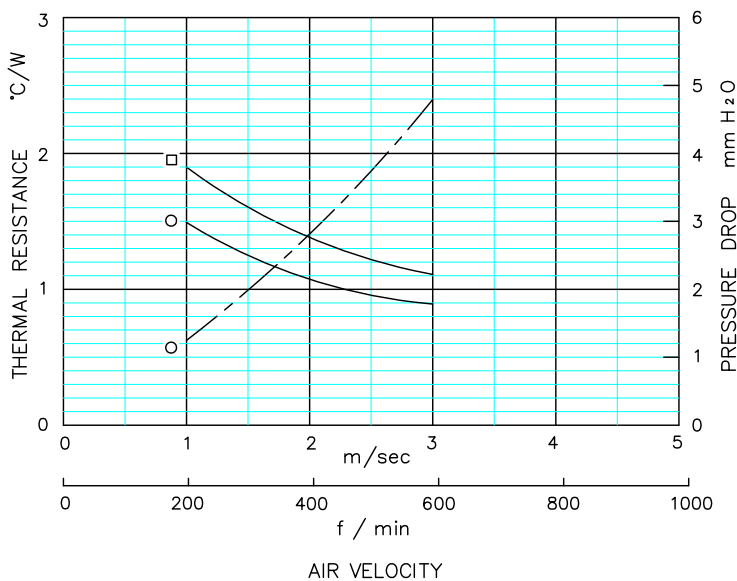

□ ZH50-9.5BP  
 ○ ZH50-12.7BP

● DUCTED CONDITION  
 DUMMY HEATER SIZE: 12.7 SQ  
 THERMAL RESISTANCE ———  
 PRESURE DROP - - - - -

■ BASED ON ALPHA'S STANDARD TEST PROCEDURE.  
 REFER TO TECHNICAL INFORMATION.

Alpha Company Ltd.

256-1 UEDA, NUMAZU-CITY SHIZUOKA-PREF., JAPAN  
 PHONE +81(55)966 0789  
 FAX +81(55)966 9192  
 E mail : alpha@micforg.co.jp  
 URL : <https://www.micforg.co.jp>

Alpha Novatech, Inc. - a subsidiary of Alpha Company.

473 Sapena Ct. #12 Santa Clara, CA 95054 USA  
 PHONE +1(408)567-8082  
 FAX +1(408)567-8053  
 E mail : sales@alphanovatech.com  
 URL : <https://www.alphanovatech.com>



# ALPHA

## Ultra-High Performance Heat Sink with attachment holes

# ZH54

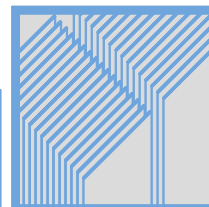

DIM

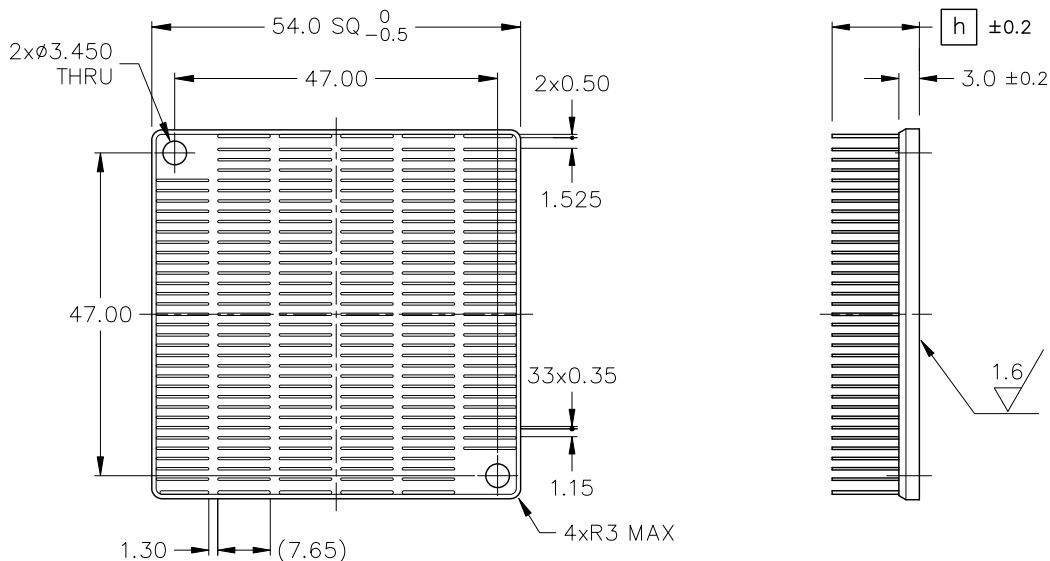

MODEL	HEIGHT $h$	WEIGHT(g)
ZH54-9.5BP	9.5	32.4
ZH54-12.7BP	12.7	37.2

MATERIAL : A 6063  
 FINISH : BLACK ANODIZE  
 DIMENSIONS : mm

DATA

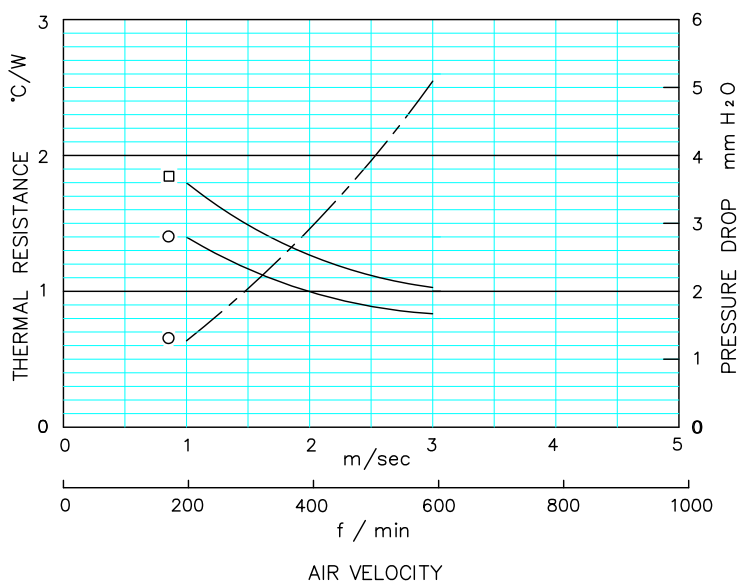

- ZH54-9.5BP
- ZH54-12.7BP

● DUCTED CONDITION  
 DUMMY HEATER SIZE: 12.7 SQ  
 THERMAL RESISTANCE ———  
 PRESURE DROP - - - - -

■ BASED ON ALPHA'S STANDARD TEST PROCEDURE.  
 REFER TO TECHNICAL INFORMATION.

Alpha Company Ltd.

256-1 UEDA, NUMAZU-CITY SHIZUOKA-PREF., JAPAN  
 PHONE +81(55)966 0789  
 FAX +81(55)966 9192  
 E mail : alpha@micforg.co.jp  
 URL : <https://www.micforg.co.jp>

Alpha Novatech, Inc. - a subsidiary of Alpha Company.

473 Sapena Ct. #12 Santa Clara, CA 95054 USA  
 PHONE +1(408)567-8082  
 FAX +1(408)567-8053  
 E mail : sales@alphanovatech.com  
 URL : <https://www.alphanovatech.com>

# ALPHA

## Ultra-High Performance Heat Sink with attachment holes

# ZH60

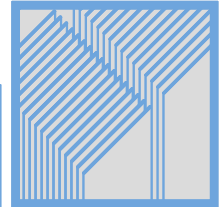

DIM

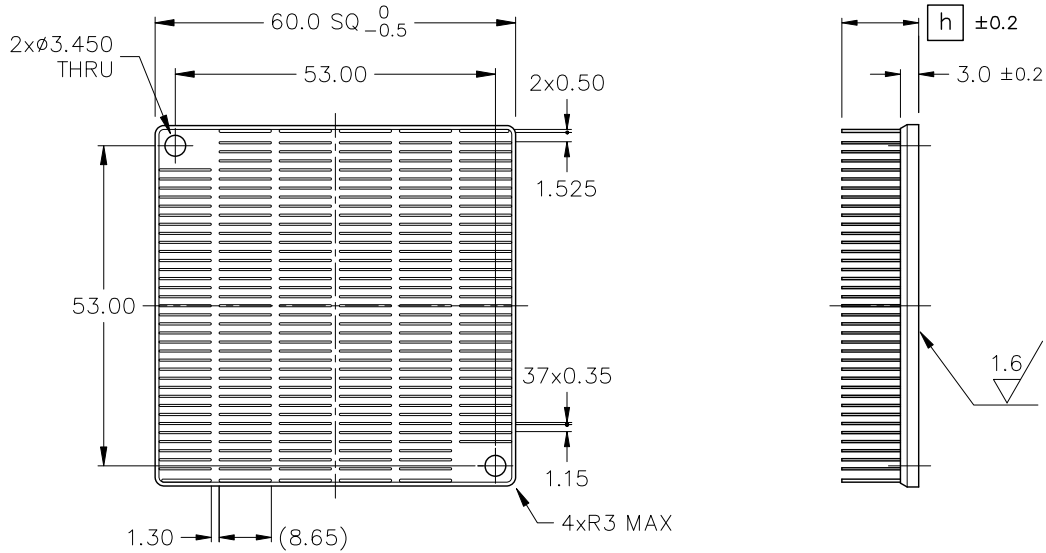

MODEL	HEIGHT [h]	WEIGHT(g)
ZH60-9.5BP	9.5	40.9
ZH60-12.7BP	12.7	46.7

MATERIAL : A 6063  
 FINISH : BLACK ANODIZE  
 DIMENSIONS : mm

DATA

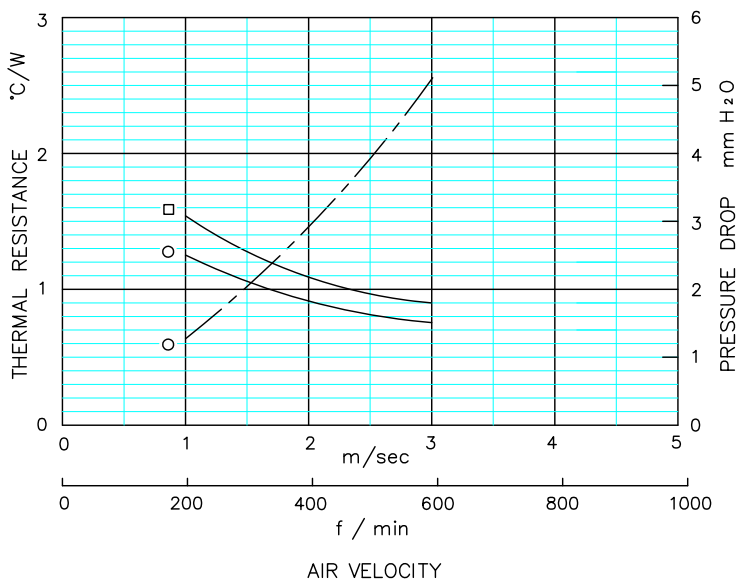

□ ZH60-9.5BP  
 ○ ZH60-12.7BP

● DUCTED CONDITION  
 DUMMY HEATER SIZE: 12.7 SQ  
 THERMAL RESISTANCE ———  
 PRESURE DROP - - - - -

■ BASED ON ALPHA'S STANDARD TEST PROCEDURE.  
 REFER TO TECHNICAL INFORMATION.

Alpha Company Ltd.

256-1 UEDA, NUMAZU-CITY SHIZUOKA-PREF., JAPAN  
 PHONE +81(55)966 0789  
 FAX +81(55)966 9192  
 E mail : alpha@micforg.co.jp  
 URL : https://www.micforg.co.jp

Alpha Novatech, Inc. - a subsidiary of Alpha Company.

473 Sapena Ct. #12 Santa Clara, CA 95054 USA  
 PHONE +1(408)567-8082  
 FAX +1(408)567-8053  
 E mail : sales@alphanovatech.com  
 URL : https://www.alphanovatech.com

REF



PCB HOLE LAYOUT

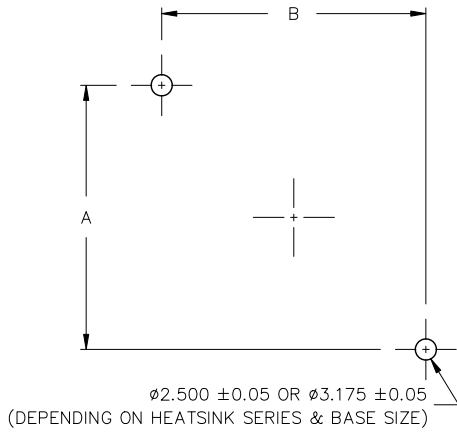

LPDH25, UBH25, ZH25	18.0	18.0
LPDH30, UBH30, ZH30	23.0	23.0
LPDH35, UBH35, ZH35	28.0	28.0
LPDH40, UBH40, ZH40	33.0	33.0
LPDH45, UBH45, ZH45	38.0	38.0
LPDH50, UBH50, ZH50, FFH50	43.0	43.0
LPDH54, UBH54, ZH54, FFH54	47.0	47.0
LPDH60, UBH60, ZH60	53.0	53.0
LPDH70, UBH70	63.0	63.0
MODEL	A	B