

REVISIONS				
REV	DATE	DESCRIPTION	CHG	APPR
/	OCT 03 '13	CHANGED BEND-SPEC (NOTE.7) OF THE FINS.	Y. S.	Y. S.

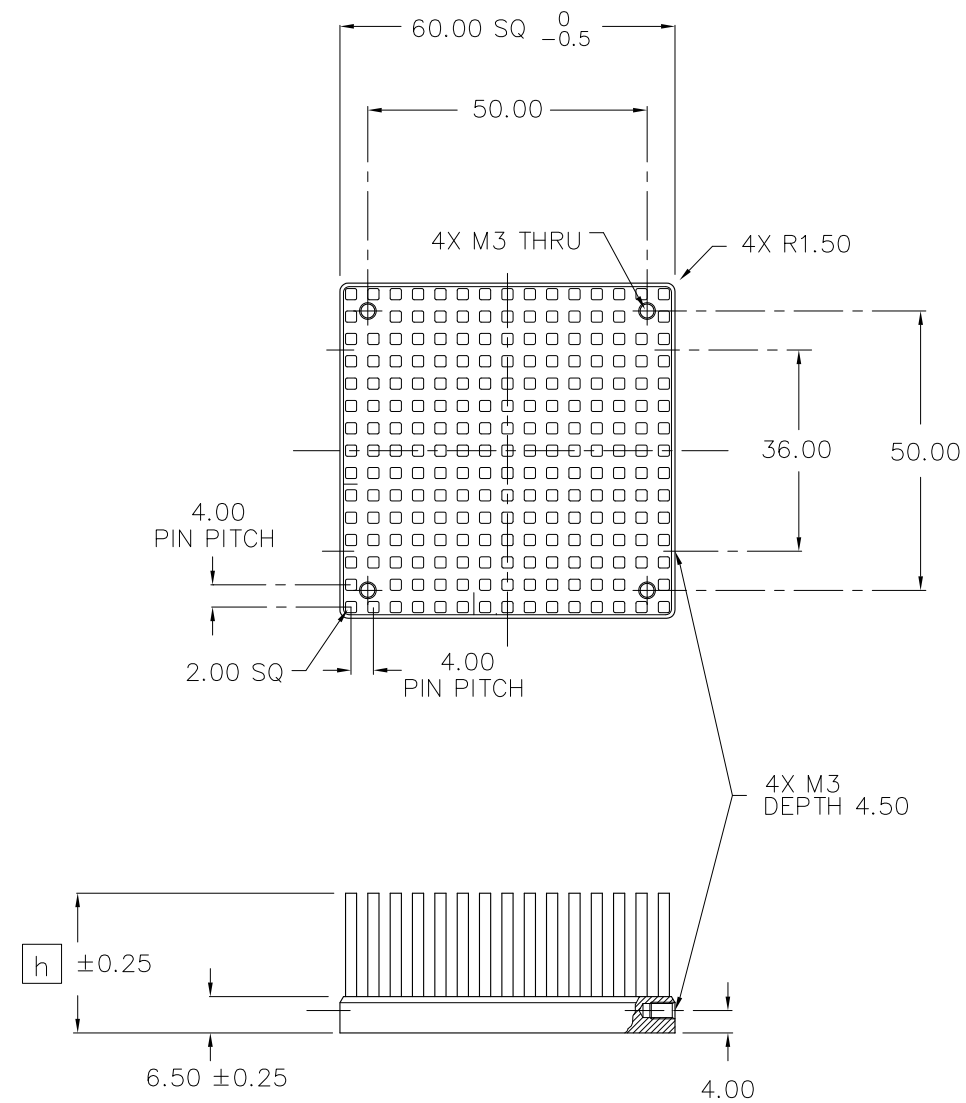

- NOTES : UNLESS OTHERWISE SPECIFIED
1. INTERPRET DIMENSIONS AND TOLERANCES PER ANSI Y14.5M-1982
 2. ALL DIMENSIONS ARE IN MILLIMETERS.
 3. MATERIAL : ALUMINUM 6063
 4. FINISH : CLEAR ANODIZE
 5. TOLERANCES :
 .XX ±0.254
 .XXX ±0.127
 ANGLES ± 1°
 6. REMOVE ALL BURRS AND BREAK SHARP EDGES.
 7. A BEND OF THE FIN: THE FINS MUST NOT CONTACT.

30	FS6030A	S001ZP0A	
20	FS6020A	S001ZP07	
HEIGHT h	MODEL NO.	PART NO.	REMARK
ALPHA CO.,LTD.		CSTM'R'S PART NO.	
	MATERIAL NOTE 3, 4	NAME FS60 XXA	
SCALE 1 : 1	APPR & CHCK Y.SUZUKI	DWG NO. S001ZP15	REV
DATE JAN 31. '05	DSGN & DWG Y.SUZUKI	RDCTN:	LOFF: