

REVISIONS				
REV	DATE	DESCRIPTION	CHG	APPR
	OCT 03 '13	CHANGED BEND-SPEC (NOTE.7) OF THE FINS.	Y. S.	Y. S.

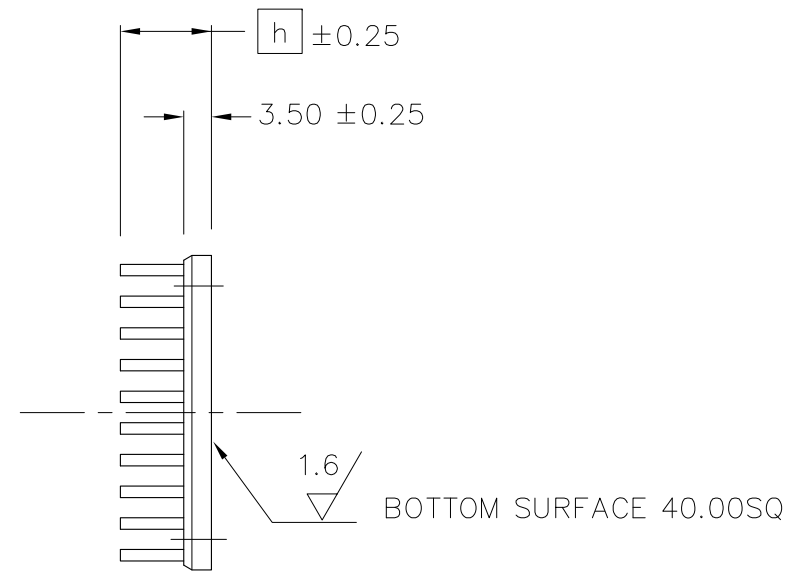
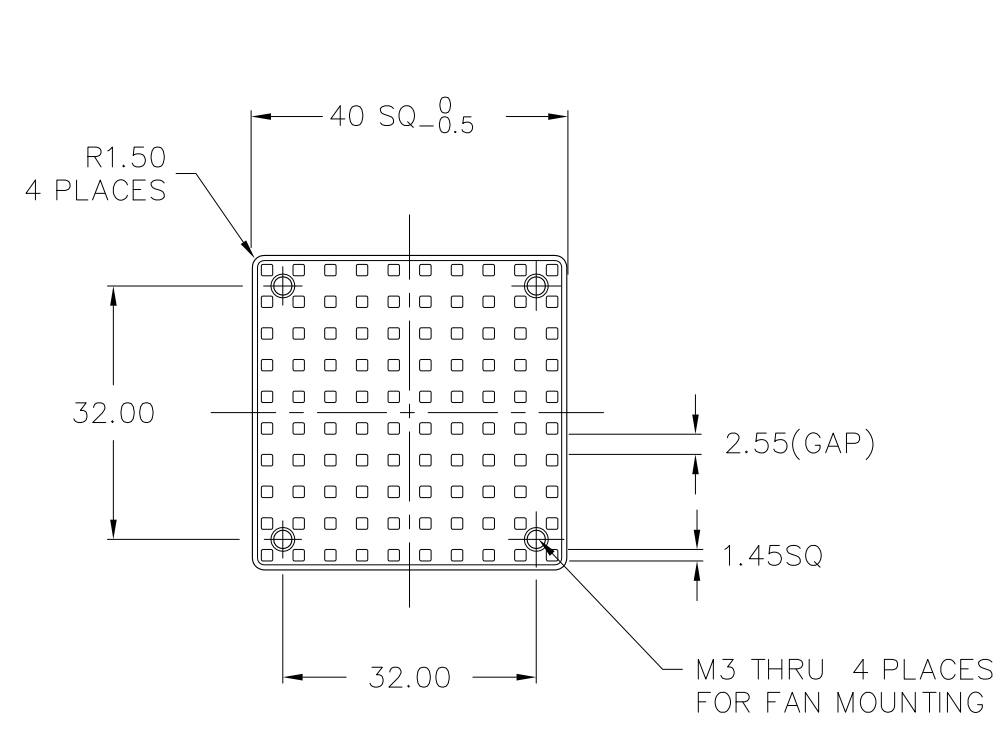

- NOTES : UNLESS OTHERWISE SPECIFIED
1. INTERPRET DIMENSIONS AND TOLERANCES PER ANSI Y14.5M
 2. ALL DIMENSIONS ARE IN MILLIMETERS.
 3. MATERIAL : ALUMINUM 6063
 4. FINISH : CLEAR ANODIZE
 5. TOLERANCES :

.XX	±0.254
.XXX	±0.127
ANGLES	± 1°
 6. REMOVE ALL BURRS AND BREAK SHARP EDGES.
UNSPECIFIED CORNER R0.5 MAX OR C0.5 MAX
 7. A BEND OF THE FIN: THE FINS MUST NOT CONTACT.

HEIGHT	MODEL NO.	PART NO.	REMARK
h			
8.0	FS40-8W	S001ZP18	
15.0	FS40-15W	S001ZP17	

ALPHA CO.,LTD.		CSTM'R'S PART NO.	
	MATERIAL NOTE 3, 4	NAME FS40-XXW	
SCALE 1 : 1	APPR & CHCK Y.SUZUKI	PART NO. & DWG NO. S001ZP16	REV
DATE AUG 08. '08	DSGN & DWG Y.SUZUKI	RDCTN:	LOFF: