

REVISIONS				
REV	DATE	DESCRIPTION	CHG	APPR
/	JUL. 20, '17	REMOVE DIMENSION OF UNDERCUTS-LENGTH FOR THREAD(WAS 1.00)	A. K.	A.K

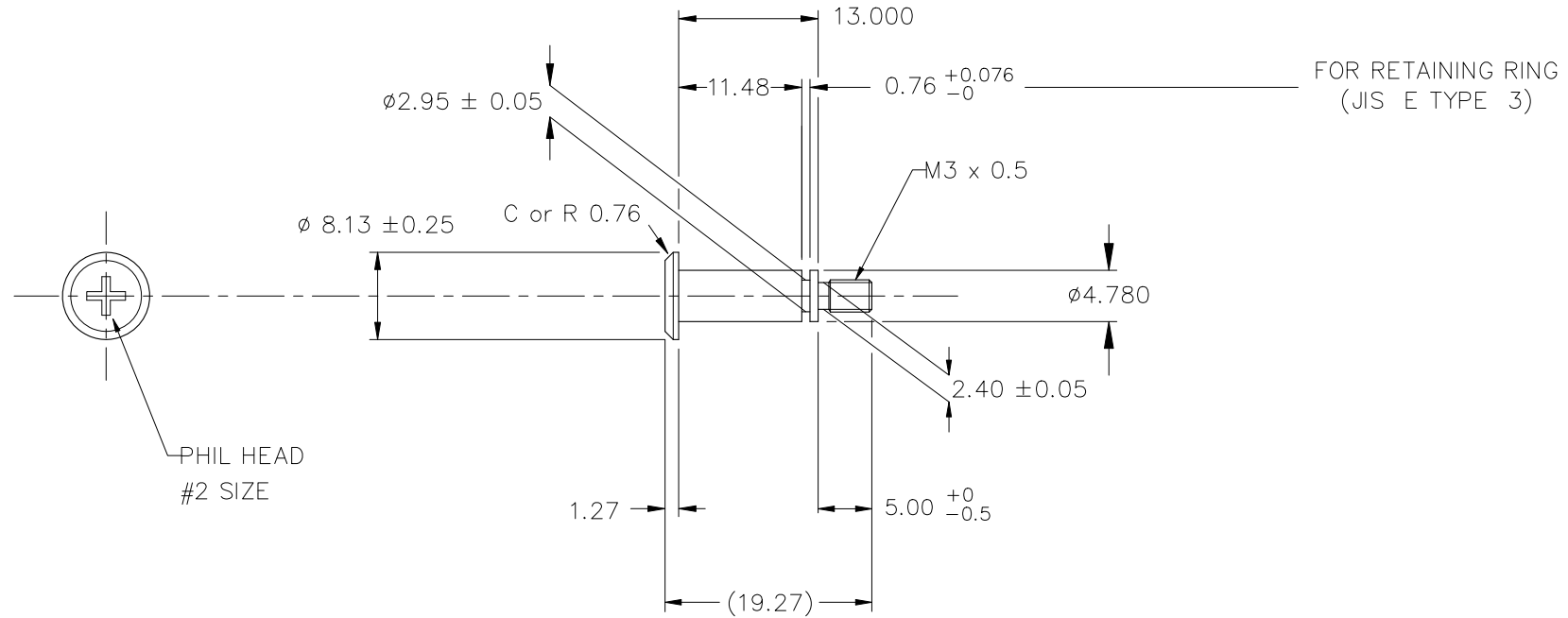

NOTES : UNLESS OTHERWISE SPECIFIED

1. INTERPRET DIMENSIONS AND TOLERANCES PER ANSI Y14.5M

2. ALL DIMENSIONS ARE IN MILLIMETERS.

3. MATERIAL

CARBON STEEL SWCH12A or EQUIVAIENT
ZINC /CLEAR CHROMATE (Cr3+)

4. TOLERANCES : .XX ± 0.254
.XXX ± 0.127

5. REMOVE ALL BURRS AND BREAK SHARP EDGES.

6. UNSPECIFIED CORNER R0.5 MAX OR C0.5 MAX

7. MACHINED SURFACE FINISH TO BE $\frac{6.3}{\nabla}$ OR BETTER.

ITEM	PART NO.	PART NAME	REMARK	Q'TY
ALPHA CO.,LTD.			CSTM'R'S PART NO.	
		MATERIAL NOTE 3	NAME SS-13-4.8-M3-5	
SCALE 2 : 1		APPR & CHCK Y.SUZUKI	PART NO. & DWG NO. S089HX1Y	REV
DATE OCT 05 2016		DSGN & DWG Y.SUZUKI	RDCTN:	LOFF:

A3