

REVISIONS				
REV	DATE	DESCRIPTION	CHG	APPR

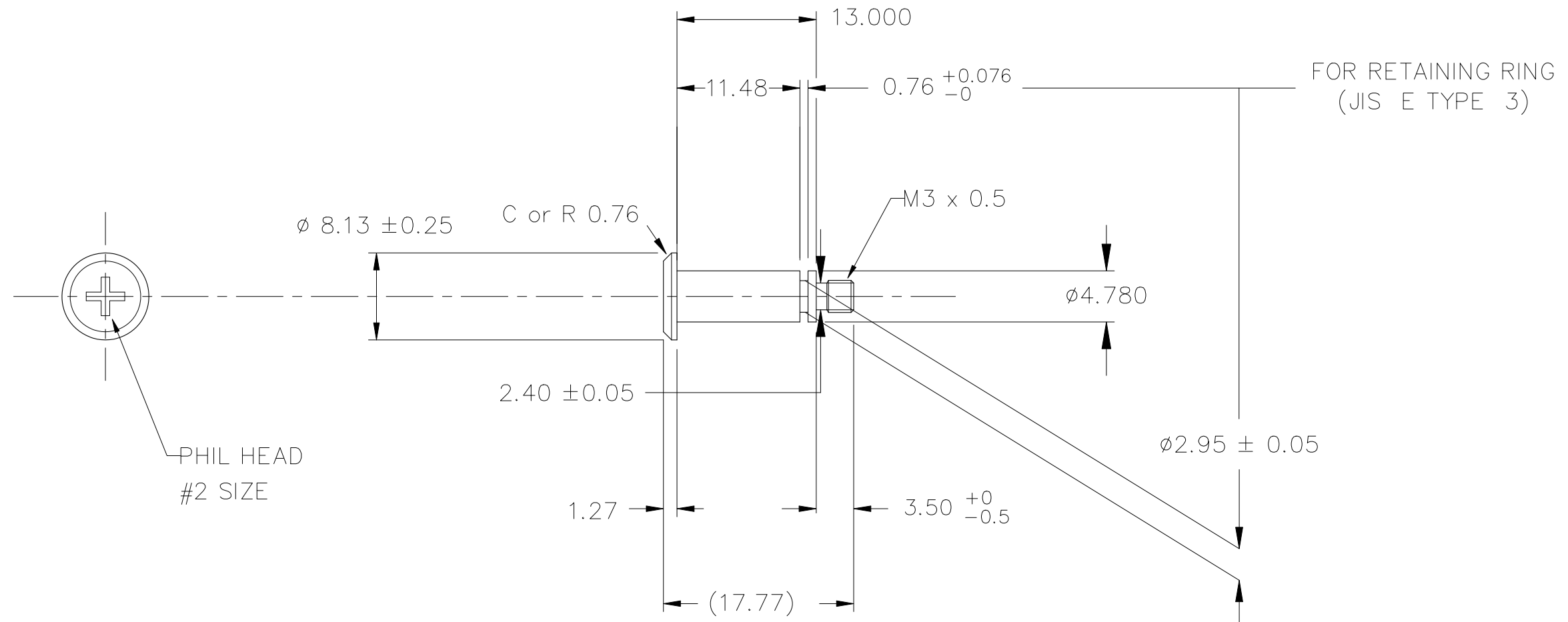

- NOTES : UNLESS OTHERWISE SPECIFIED
1. INTERPRET DIMENSIONS AND TOLERANCES PER ANSI Y14.5M
 2. ALL DIMENSIONS ARE IN MILLIMETERS.
 3. MATERIAL
CARBON STEEL SWCH12A or EQUIVAIENT
ZINC /CLEAR CHROMATE (Cr3+)
 4. TOLERANCES :
.XX ±0.254
.XXX ±0.127
 5. REMOVE ALL BURRS AND BREAK SHARP EDGES.
 6. UNSPECIFIED CORNER R0.5 MAX OR C0.5 MAX
 7. MACHINED SURFACE FINISH TO BE $\sqrt{6.3}$ OR BETTER.

ITEM	PART NO.	PART NAME	REMARK	Q'TY
ALPHA CO.,LTD.			CSTM'R'S PART NO.	
		MATERIAL NOTE 3	NAME SS-13-4.8-M3-3.5	
SCALE 2 : 1		APPR & CHCK T. YANAGIDAIRA	PART NO. & DWG NO. S089HX29	REV
DATE MAY 25, 2020		DSGN & DWG T. YANAGIDAIRA	RDCTN:	LOFF:

A3