

REVISIONS				
REV	DATE	DESCRIPTION	CHG	APPR

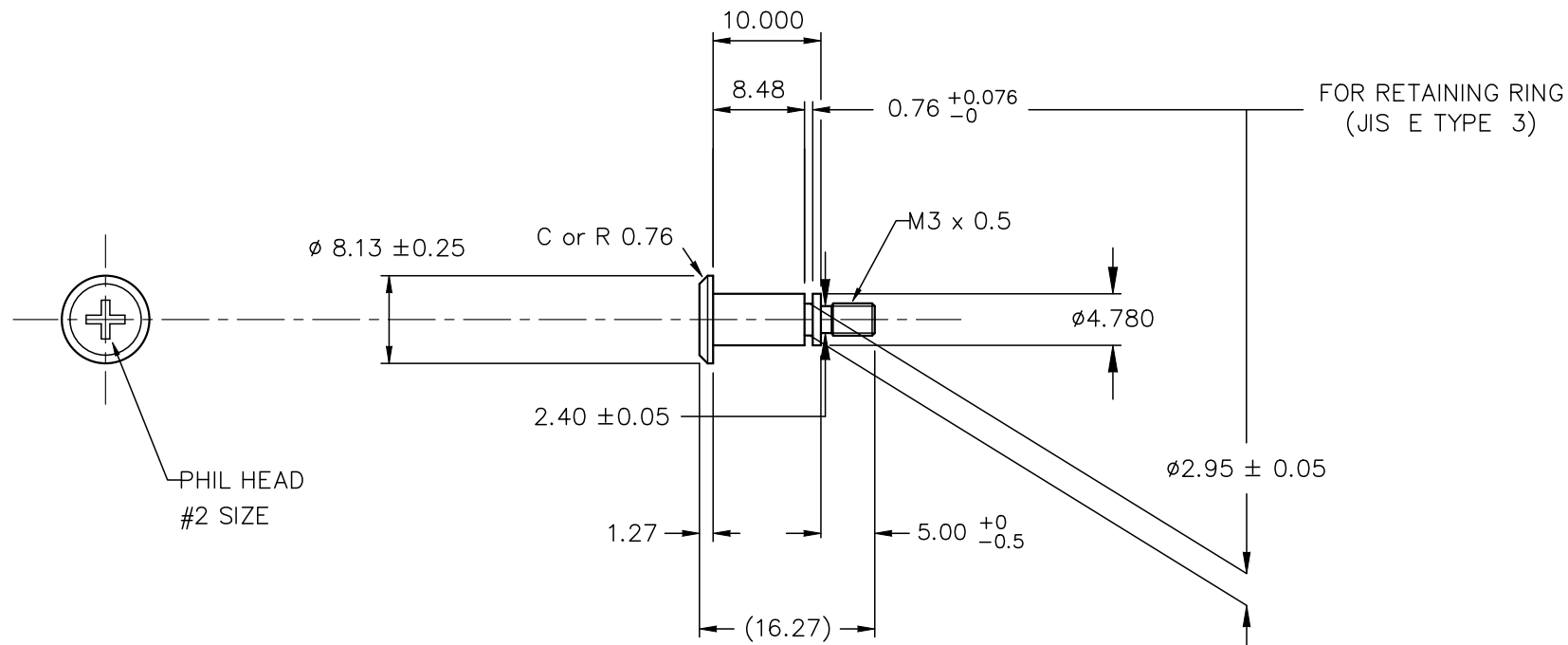

NOTES : UNLESS OTHERWISE SPECIFIED

1. INTERPRET DIMENSIONS AND TOLERANCES PER ANSI Y14.5M

2. ALL DIMENSIONS ARE IN MILLIMETERS.

3. MATERIAL

CARBON STEEL SWCH12A or EQUIVAIENT
ZINC /CLEAR CHROMATE (Cr3+)

4. TOLERANCES : .XX ± 0.254
.XXX ± 0.127

5. REMOVE ALL BURRS AND BREAK SHARP EDGES.

6. UNSPECIFIED CORNER R0.5 MAX OR C0.5 MAX

7. MACHINED SURFACE FINISH TO BE $\frac{6.3}{\sqrt{\quad}}$ OR BETTER.

ITEM	PART NO.	PART NAME	REMARK	Q'TY
ALPHA CO.LTD.			CSTMR'S PART NO.	
	MATERIAL NOTE 3		NAME SS-10-4.8-M3-5	
SCALE 2 : 1	APPR & CHCK M.YAMAMOTO	PART NO. & DWG NO. S089HX2G		REV
DATE MAY 07. 2022	DSGN & DWG M.YAMAMOTO	RDCTN:	LOFF:	