

REVISIONS				
REV	DATE	DESCRIPTION	CHG	APPR

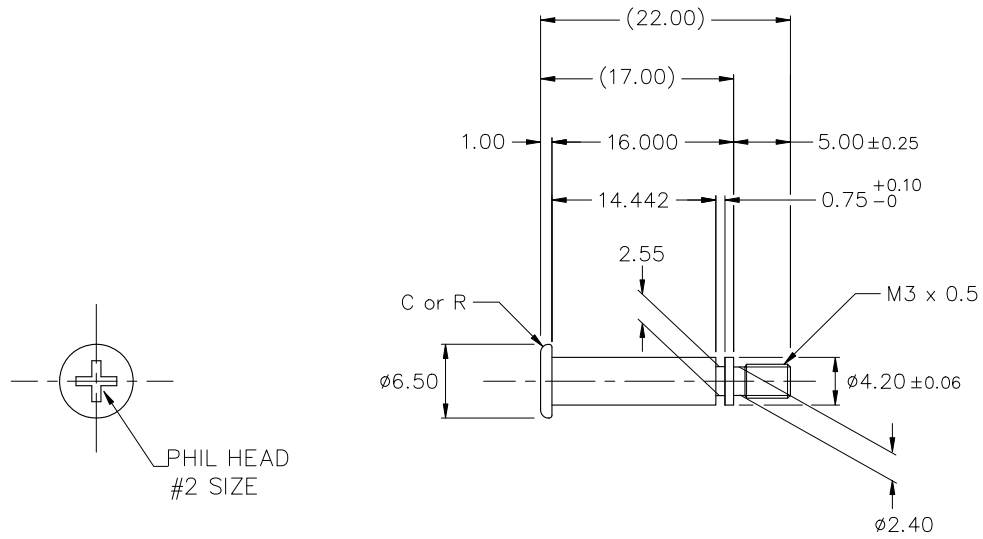

NOTES : UNLESS OTHERWISE SPECIFIED

1. INTERPRET DIMENSIONS AND TOLERANCES PER ANSI Y14.5M

2. ALL DIMENSIONS ARE IN MILLIMETERS.

3. MATERIAL

CARBON STEEL SWCH12A or EQUIVALENT
ZINC /CLEAR CHROMATE (Cr3+)

4. TOLERANCES : .XX ±0.254
.XXX ±0.127

5. REMOVE ALL BURRS AND BREAK SHARP EDGES.

6. UNSPECIFIED CORNER R0.5 MAX OR C0.5 MAX

7. MACHINED SURFACE FINISH TO BE 6.3/√ OR BETTER.

ITEM	PART NO.	PART NAME	REMARK	Q'TY
ALPHA CO.,LTD.			CSTM'R'S PART NO.	
		MATERIAL NOTE 3	NAME SS-16-4.2-M3-5	
SCALE 2 : 1		APPR & CHCK A.KATSUMATA	PART NO. & DWG NO. S089HX2H	REV
DATE 2022.07.04		DSGN & DWG A.KATSUMATA	RDCTN:	LOFF:

A3