

REVISIONS				
REV	DATE	DESCRIPTION	CHG	APPR

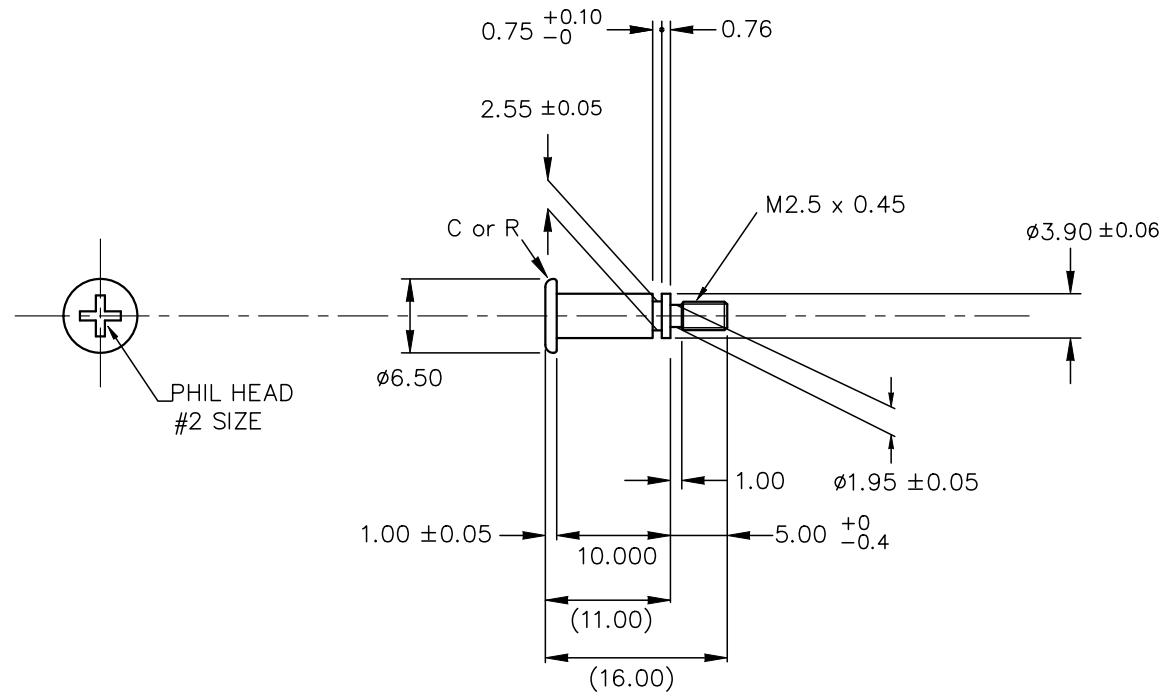

NOTES : UNLESS OTHERWISE SPECIFIED

1. INTERPRET DIMENSIONS AND TOLERANCES PER ANSI Y14.5M

2. ALL DIMENSIONS ARE IN MILLIMETERS.

3. MATERIAL

CARBON STEEL SWCH12A or EQUIVAIENT  
ZINC /CLEAR CHROMATE ( Cr3+ )

4. TOLERANCES : .XX ±0.254  
.XXX ±0.127

5. REMOVE ALL BURRS AND BREAK SHARP EDGES.

6. UNSPECIFIED CORNER R0.5 MAX OR C0.5 MAX

7. MACHINED SURFACE FINISH TO BE  $\sqrt{6.3}$  OR BETTER.

ITEM	PART NO.	PART NAME	REMARK	Q'TY
<b>ALPHA CO.,LTD.</b>			CSTM'R'S PART NO.	
		MATERIAL NOTE 3	NAME SS-10-3.9-M2.5-5	
SCALE 2 : 1		APPR & CHCK T. SUZUKI	PART NO. & DWG NO. S089HX2N	REV
DATE JUN 02, 2023		DSGN & DWG T. SUZUKI	RDCTN:	LOFF: