

UBC Series

Low Pressure Drop and

Low Thermal Resistance Heat Sink

Copper (Heat spreader) Embedded Type

ALPHA

ALPHA

Low Profile Heat Sink Copper Embedded Type

UBC 60

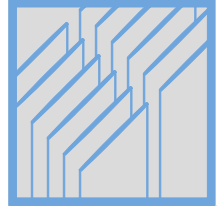

DIM

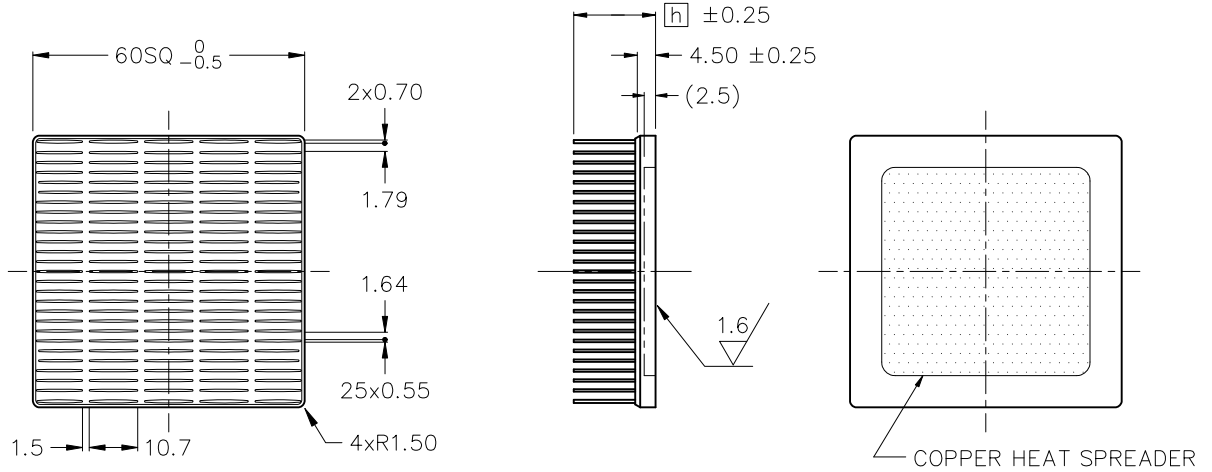

MATERIAL : ALUMINUM 6063
COPPER C1100 or C1020

FINISH : B* = BLACK ANODIZE
(EXCEPT BOTTOM SURFACE)
N* = NO SURFACE FINISH
* : MODEL SUFFIX

MODEL	HEIGHT h	WEIGHT (grams)
UBC60-10B, UBC60-10N	10	85.0
UBC60-12B, UBC60-12N	12	88.4
UBC60-15B, UBC60-15N	15	93.5
UBC60-20B, UBC60-20N	20	102.0
UBC60-25B, UBC60-25N	25	111.0

Dimensions : mm

DATA

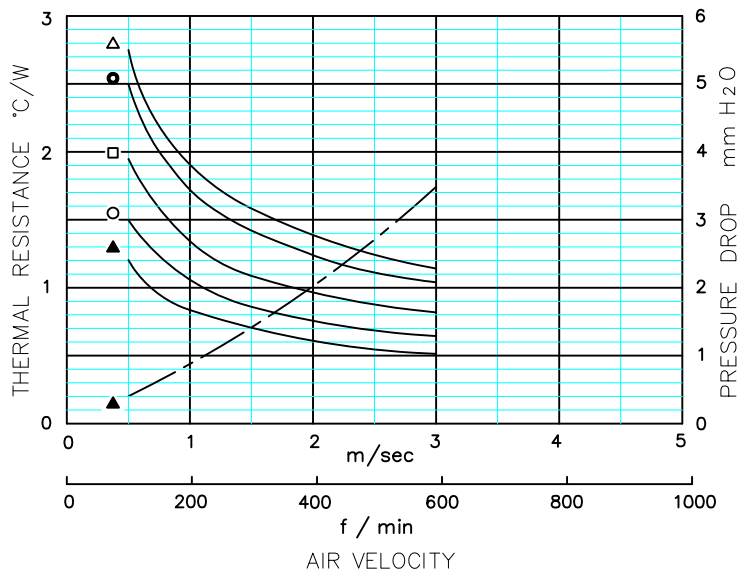

- △ UBC60-10B, UBC60-10N
- UBC60-12B, UBC60-12N
- UBC60-15B, UBC60-15N
- ◇ UBC60-20B, UBC60-20N
- ▲ UBC60-25B, UBC60-25N

● DUCTED CONDITION
DUMMY HEATER SIZE: 25.4 SQ
THERMAL RESISTANCE ———
PRESSURE DROP - - - - -

■ BASED ON ALPHA'S STANDARD TEST PROCEDURE.
REFER TO TECHNICAL INFORMATION.

Alpha Company Ltd.

256-1 UEDA, NUMAZU-CITY SHIZUOKA-PREF., JAPAN
PHONE +81(55)966 0789
FAX +81(55)966 9192
E mail : alpha@micforg.co.jp
URL : <https://www.micforg.co.jp>

Alpha Novatech, Inc. - a subsidiary of Alpha Company.

473 Sapena Ct. #12 Santa Clara, CA 95054 USA
PHONE +1(408)567-8082
FAX +1(408)567-8053
E mail : sales@alphanovatech.com
URL : <https://www.alphanovatech.com>

ALPHA

Low Profile Heat Sink Copper Embedded Type

UBC100

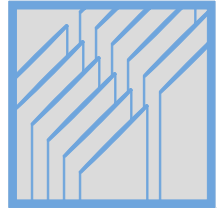

DIM

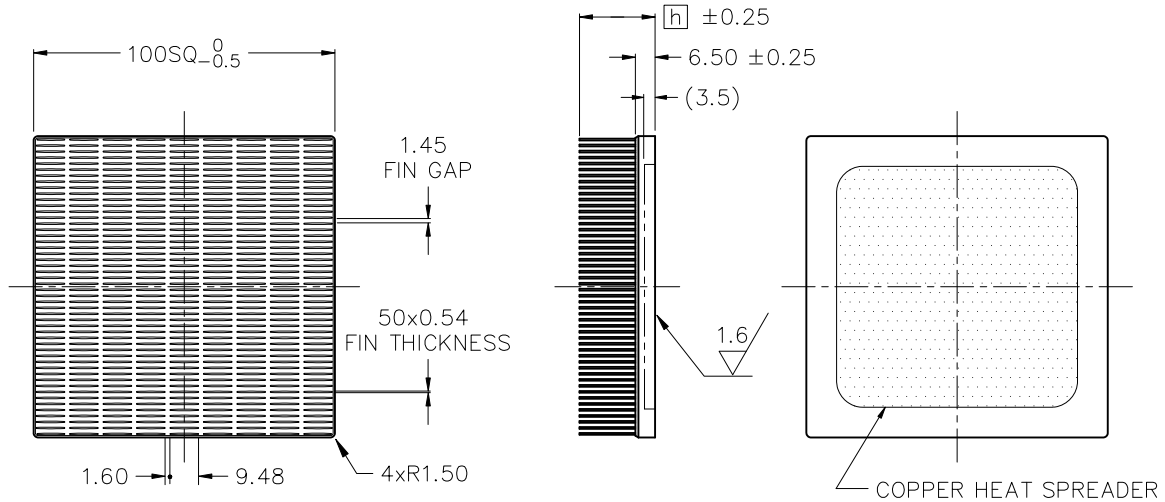

MATERIAL : ALUMINUM 6063
COPPER C1100 or C1020

FINISH : B* = BLACK ANODIZE
(EXCEPT BOTTOM SURFACE)
N* = NO SURFACE FINISH
* : MODEL SUFFIX

MODEL	HEIGHT h	WEIGHT (grams)
UBC100-15B, UBC100-15N	15	288.3
UBC100-20B, UBC100-20N	20	326.0
UBC100-25B, UBC100-25N	25	363.7

Dimensions : mm

DATA

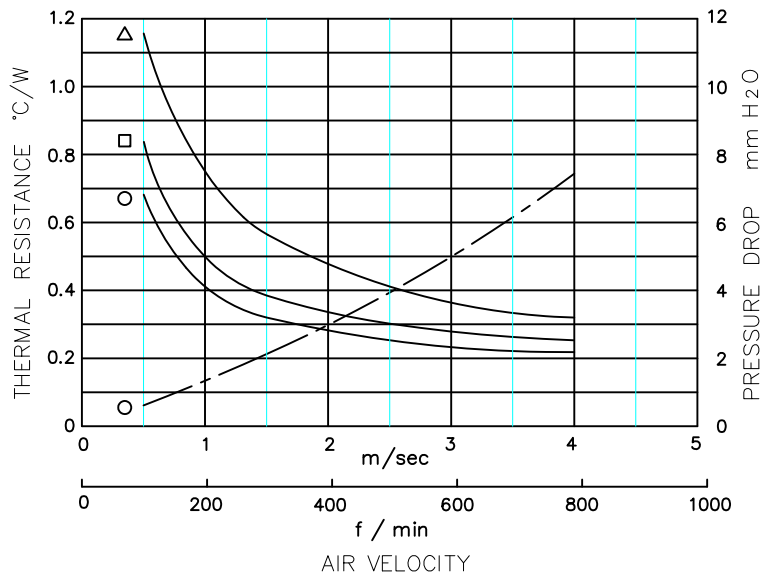

\bullet DUCTED CONDITION
DUMMY HEATER SIZE: 25.4 SQ
THERMAL RESISTANCE (solid line)
PRESSURE DROP (dashed line)

\blacksquare BASED ON ALPHA'S STANDARD TEST PROCEDURE.
REFER TO TECHNICAL INFORMATION.

Alpha Company Ltd.

256-1 UEDA, NUMAZU-CITY SHIZUOKA-PREF., JAPAN
PHONE +81(55)966 0789
FAX +81(55)966 9192
E mail : alpha@micforg.co.jp
URL : <https://www.micforg.co.jp>

Alpha Novatech, Inc. - a subsidiary of Alpha Company.

473 Sapena Ct. #12 Santa Clara, CA 95054 USA
PHONE +1(408)567-8082
FAX +1(408)567-8053
E mail : sales@alphanovatech.com
URL : <https://www.alphanovatech.com>