

ULP Series

Balance between low thermal
resistance Low pressure drop

ALPHA

ALPHA

Balance between low thermal resistance Low pressure drop

ULP50

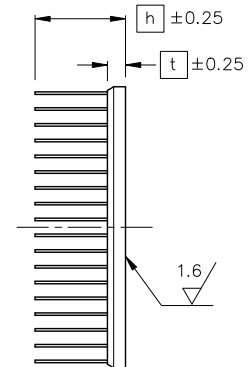
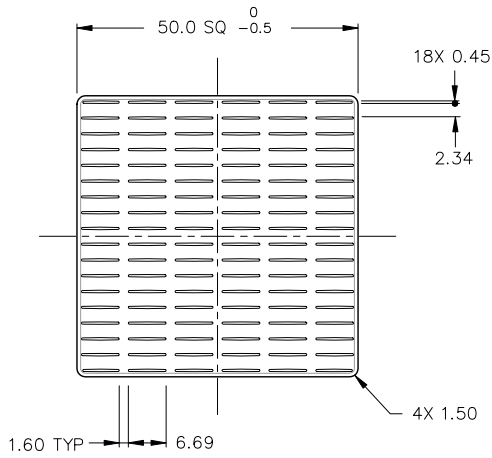
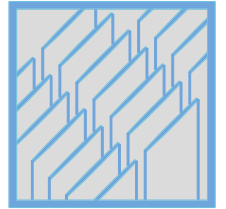

MATERIAL : A6063
 FINISH : BLACK ANODIZE
 DIMENSIONS : mm

MODEL	HEIGHT [h]	THICKNESS [t]	WEIGHT (grams)
ULP50-6B	6	2.50	18.1
ULP50-8B	8		18.9
ULP50-10B	10		26.0
ULP50-12B	12	3.50	26.8
ULP50-15B	15		28.0
ULP50-20B	20		30.0
ULP50-[h]B	[h] ≤ 9	2.50	-
	9 < [h] ≤ 20	3.50	-

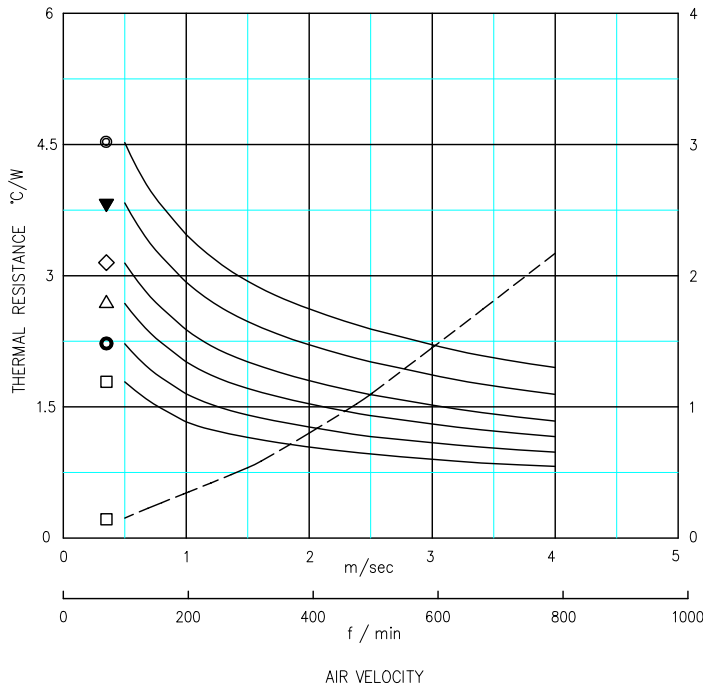

- ULP50-6B
- ▼ ULP50-8B
- ◇ ULP50-10B
- △ ULP50-12B
- ULP50-15B
- ULP50-20B

● DUCTED CONDITION
 DUMMY HEATER SIZE: 12.7 SQ
 THERMAL RESISTANCE ———
 PRESURE DROP - - - -

■ BASED ON ALPHA'S STANDARD TEST PROCEDURE.
 REFER TO TECHNICAL INFORMATION.

Alpha Company Ltd.

256-1 UEDA, NUMAZU-CITY SHIZUOKA-PREF., JAPAN
 PHONE +81(55)966 0789
 FAX +81(55)966 9192
 E mail : alpha@micforg.co.jp
 URL : https://www.micforg.co.jp

Alpha Novatech, Inc. - a subsidiary of Alpha Company.

473 Sapena Ct. #12 Santa Clara, CA 95054 USA
 PHONE +1(408)567-8082
 FAX +1(408)567-8053
 E mail : sales@alphanovatech.com
 URL : https://www.alphanovatech.com

ALPHA

Balance between low thermal resistance Low pressure drop

ULP60

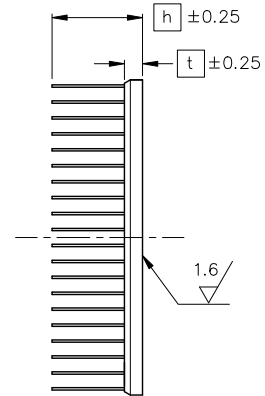
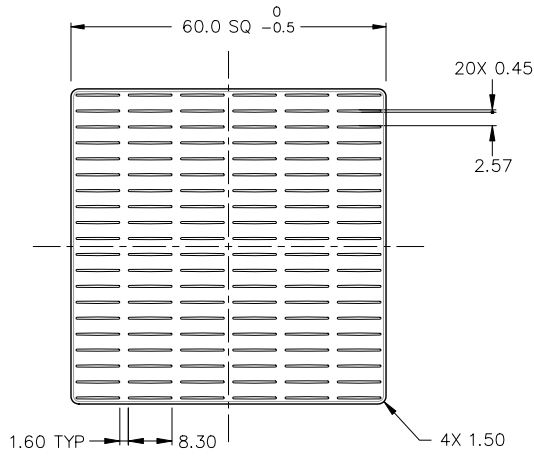
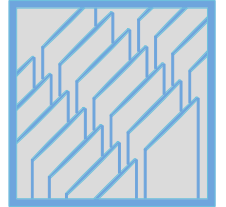

MATERIAL : A6063
 FINISH : BLACK ANODIZE
 DIMENSIONS : mm

MODEL	HEIGHT [h]	THICKNESS [t]	WEIGHT (grams)
ULP60-6B	6	3.00	30.5
ULP60-8B	8		31.7
ULP60-10B	10		41.8
ULP60-12B	12	4.00	42.9
ULP60-15B	15		44.6
ULP60-20B	20		47.4
ULP60-[h]B	$h \leq 9$	3.00	-
	$9 < h \leq 20$	4.00	-

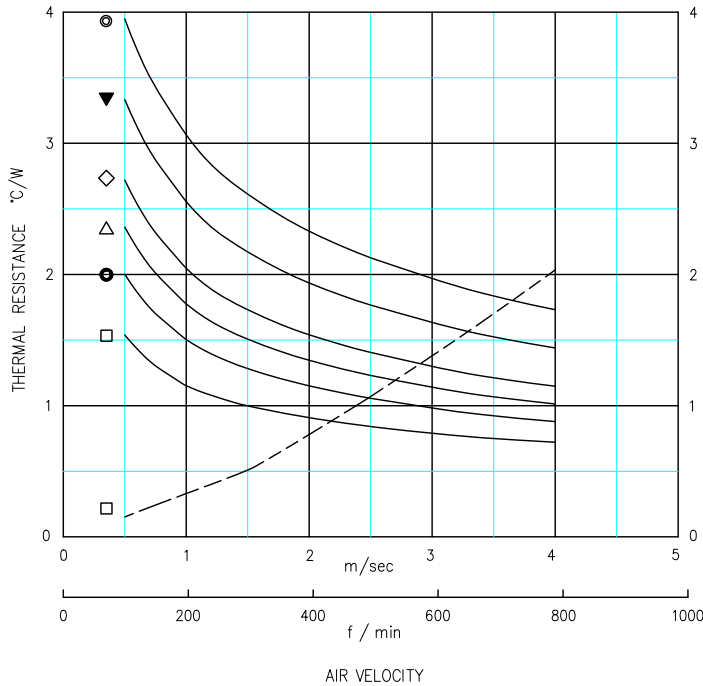

- ⊙ ULP60-6B
- ▼ ULP60-8B
- ◇ ULP60-10B
- △ ULP60-12B
- ULP60-15B
- ULP60-20B

● DUCTED CONDITION
 DUMMY HEATER SIZE: 12.7 SQ
 THERMAL RESISTANCE ———
 PRESURE DROP - - - - -

■ BASED ON ALPHA'S STANDARD TEST PROCEDURE.
 REFER TO TECHNICAL INFORMATION.

Alpha Company Ltd.

256-1 UEDA, NUMAZU-CITY SHIZUOKA-PREF., JAPAN
 PHONE +81(55)966 0789
 FAX +81(55)966 9192
 E mail : alpha@micforg.co.jp
 URL : <https://www.micforg.co.jp>

Alpha Novatech, Inc. - a subsidiary of Alpha Company.

473 Sapena Ct. #12 Santa Clara, CA 95054 USA
 PHONE +1(408)567-8082
 FAX +1(408)567-8053
 E mail : sales@alphanovatech.com
 URL : <https://www.alphanovatech.com>

ALPHA

Balance between low thermal resistance Low pressure drop

ULP 70

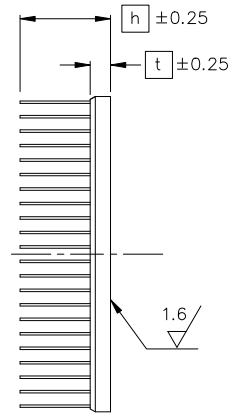
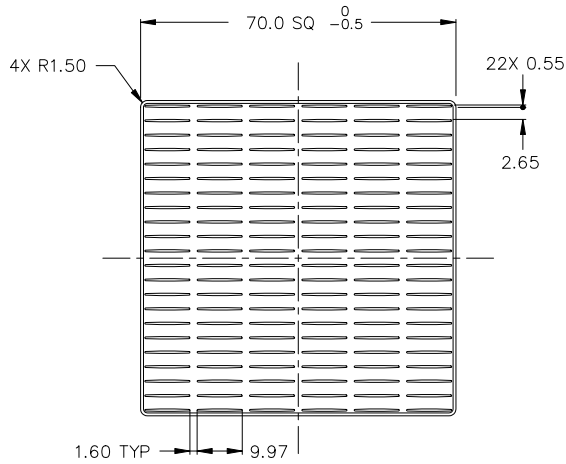
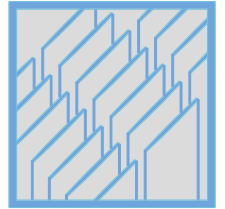

MATERIAL : A6063
 FINISH : BLACK ANODIZE
 DIMENSIONS : mm

MODEL	HEIGHT [h]	THICKNESS [t]	WEIGHT (grams)
ULP70-8B	8	3.00	47.9
ULP70-10B	10		51.3
ULP70-12B	12		54.7
ULP70-15B	15	4.50	76.9
ULP70-20B	20		85.4
ULP70-25B	25		93.9
ULP70-[h]B	[h] ≤ 12	3.00	-
	12 < [h] ≤ 25	4.50	-

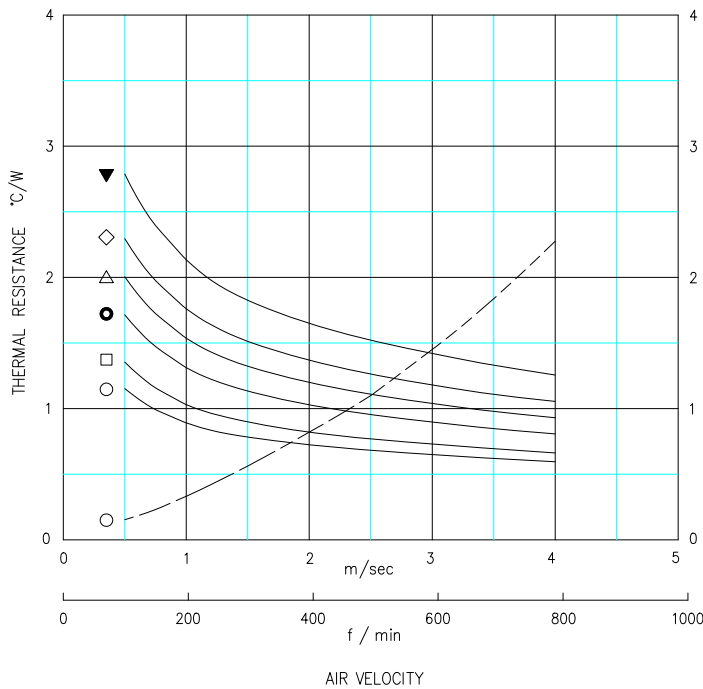

- ▼ ULP70-8B
 - ◇ ULP70-10B
 - △ ULP70-12B
 - ULP70-15B
 - ULP70-20B
 - ULP70-25B
- DUCTED CONDITION
 DUMMY HEATER SIZE: 12.7 SQ
 THERMAL RESISTANCE ———
 PRESSURE DROP - - - -

■ BASED ON ALPHA'S STANDARD TEST PROCEDURE.
 REFER TO TECHNICAL INFORMATION.

Alpha Company Ltd.

256-1 UEDA, NUMAZU-CITY SHIZUOKA-PREF., JAPAN
 PHONE +81(55)966 0789
 FAX +81(55)966 9192
 E mail : alpha@micforg.co.jp
 URL : <https://www.micforg.co.jp>

Alpha Novatech, Inc. - a subsidiary of Alpha Company.

473 Sapena Ct. #12 Santa Clara, CA 95054 USA
 PHONE +1(408)567-8082
 FAX +1(408)567-8053
 E mail : sales@alphanovatech.com
 URL : <https://www.alphanovatech.com>

ALPHA

Balance between low thermal resistance Low pressure drop

ULP 80

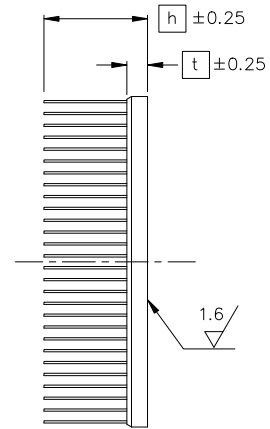
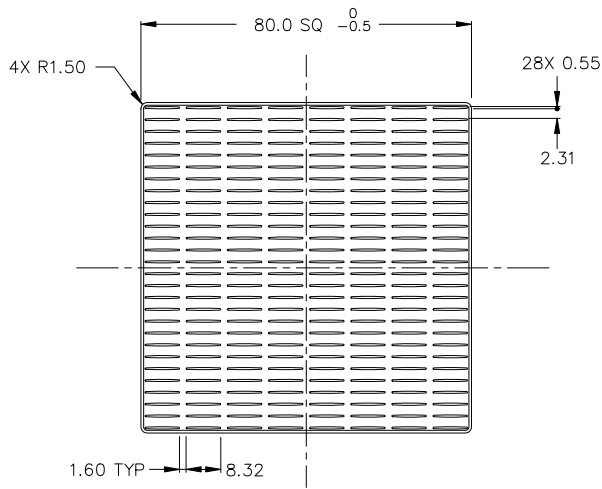
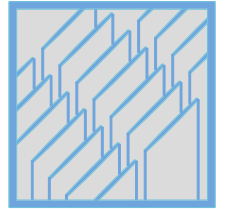

MATERIAL : A6063
 FINISH : BLACK ANODIZE
 DIMENSIONS : mm

MODEL	HEIGHT [h]	THICKNESS [t]	WEIGHT (grams)
ULP80-8B	8	4.00	78.2
ULP80-10B	10		83.0
ULP80-12B	12		87.8
ULP80-15B	15	5.00	109.8
ULP80-20B	20		121.8
ULP80-25B	25		133.9
ULP80-[h]B	[h] ≤ 12	4.00	-
	12 < [h] ≤ 25	5.00	-

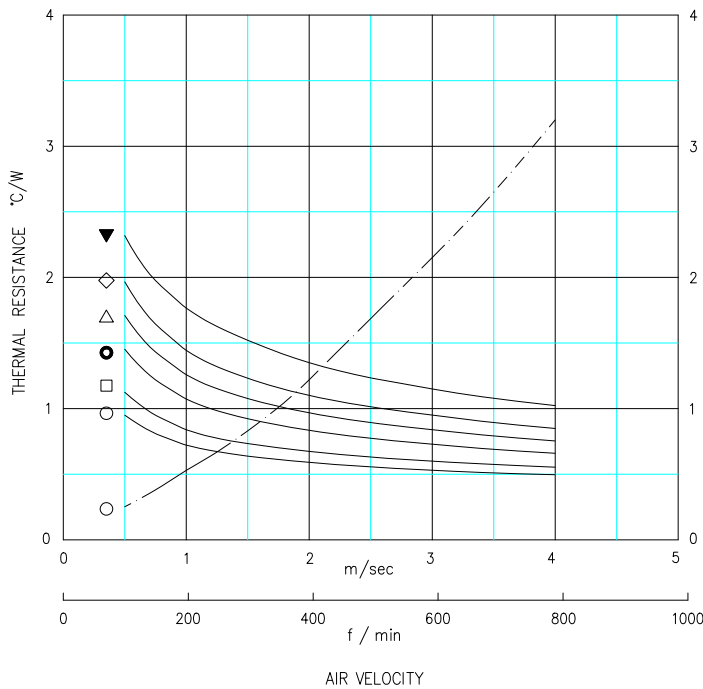

▼ ULP80-8B
 ◇ ULP80-10B
 △ ULP80-12B
 ● ULP80-15B
 □ ULP80-20B
 ○ ULP80-25B
 ● DUCTED CONDITION
 DUMMY HEATER SIZE: 12.7 SQ
 THERMAL RESISTANCE ———
 PRESSURE DROP - - -
 ■ BASED ON ALPHA'S STANDARD TEST PROCEDURE.
 REFER TO TECHNICAL INFORMATION.

Alpha Company Ltd.

256-1 UEDA, NUMAZU-CITY SHIZUOKA-PREF., JAPAN
 PHONE +81(55)966 0789
 FAX +81(55)966 9192
 E mail : alpha@micforg.co.jp
 URL : <https://www.micforg.co.jp>

Alpha Novatech, Inc. - a subsidiary of Alpha Company.

473 Sapena Ct. #12 Santa Clara, CA 95054 USA
 PHONE +1(408)567-8082
 FAX +1(408)567-8053
 E mail : sales@alphanovatech.com
 URL : <https://www.alphanovatech.com>

ALPHA

Balance between low thermal resistance Low pressure drop

ULP90

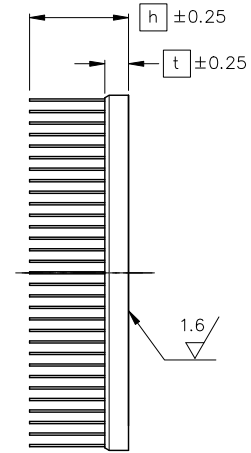
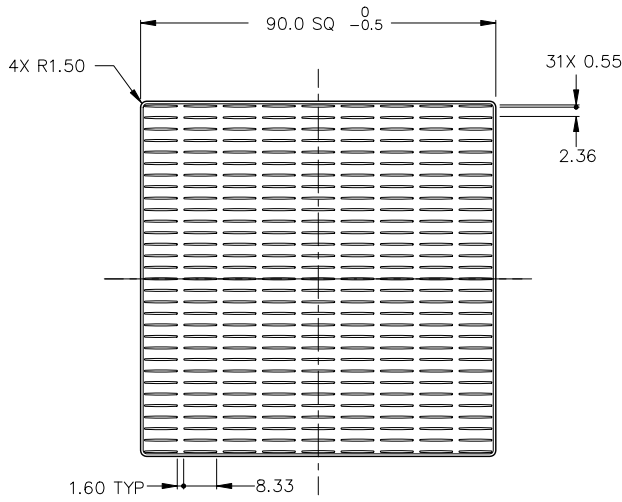
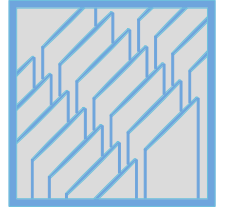

MATERIAL : A6063
 FINISH : BLACK ANODIZE
 DIMENSIONS : mm

MODEL	HEIGHT [h]	THICKNESS [t]	WEIGHT (grams)
ULP90-8B	8	4.00	98.9
ULP90-10B	10		104.9
ULP90-12B	12		110.9
ULP90-15B	15	6.00	157.3
ULP90-20B	20		172.3
ULP90-25B	25		187.3
ULP90-[h]B	[h] ≤ 12	4.00	-
	12 < [h] ≤ 25	6.00	-

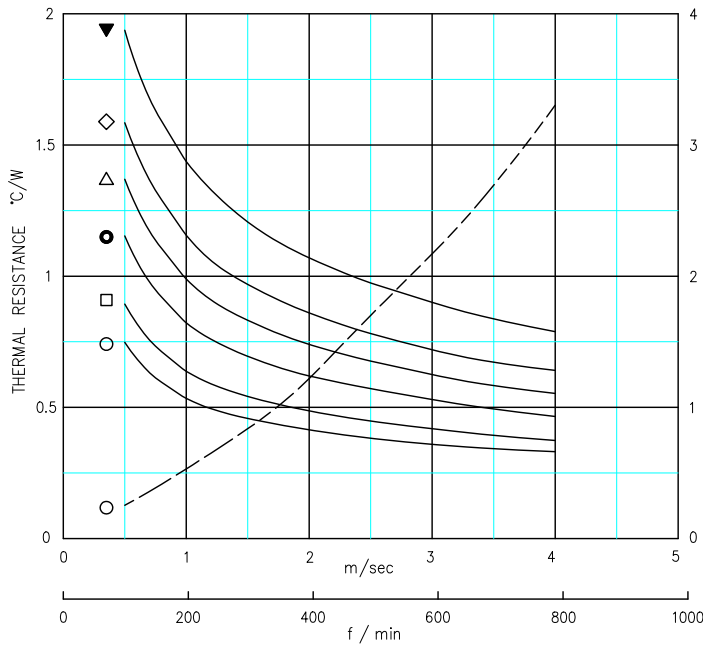

▼ ULP90-8B
 ◇ ULP90-10B
 △ ULP90-12B
 ● ULP90-15B
 □ ULP90-20B
 ○ ULP90-25B

● DUCTED CONDITION
 DUMMY HEATER SIZE: 12.7 SQ
 THERMAL RESISTANCE ———
 PRESURE DROP - - - -

■ BASED ON ALPHA'S STANDARD TEST PROCEDURE.
 REFER TO TECHNICAL INFORMATION.

Alpha Company Ltd.

256-1 UEDA, NUMAZU-CITY SHIZUOKA-PREF., JAPAN
 PHONE +81(55)966 0789
 FAX +81(55)966 9192
 E mail : alpha@micforg.co.jp
 URL : <https://www.micforg.co.jp>

Alpha Novatech, Inc. - a subsidiary of Alpha Company.

473 Sapena Ct. #12 Santa Clara, CA 95054 USA
 PHONE +1(408)567-8082
 FAX +1(408)567-8053
 E mail : sales@alphanovatech.com
 URL : <https://www.alphanovatech.com>

ALPHA

Balance between low thermal resistance Low pressure drop

ULP100

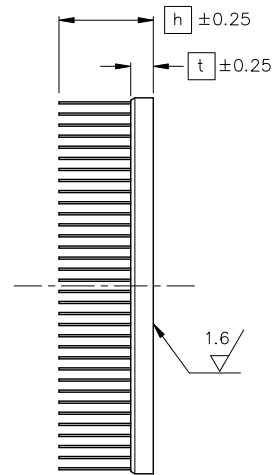
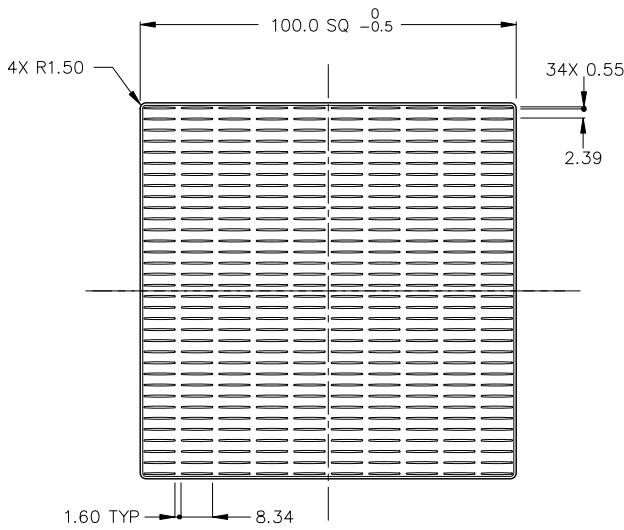
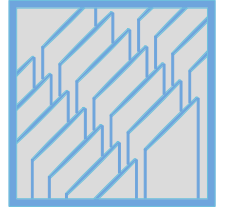

MATERIAL : A6063
 FINISH : BLACK ANODIZE
 DIMENSIONS : mm

MODEL	HEIGHT [h]	THICKNESS [t]	WEIGHT (grams)
ULP100-10B	10	4.50	140.9
ULP100-12B	12		148.2
ULP100-15B	15		194.0
ULP100-20B	20	6.00	212.3
ULP100-25B	25		230.6
ULP100-[h]B	[h] ≤ 12	4.00	-
	12 < [h] ≤ 25	6.00	-

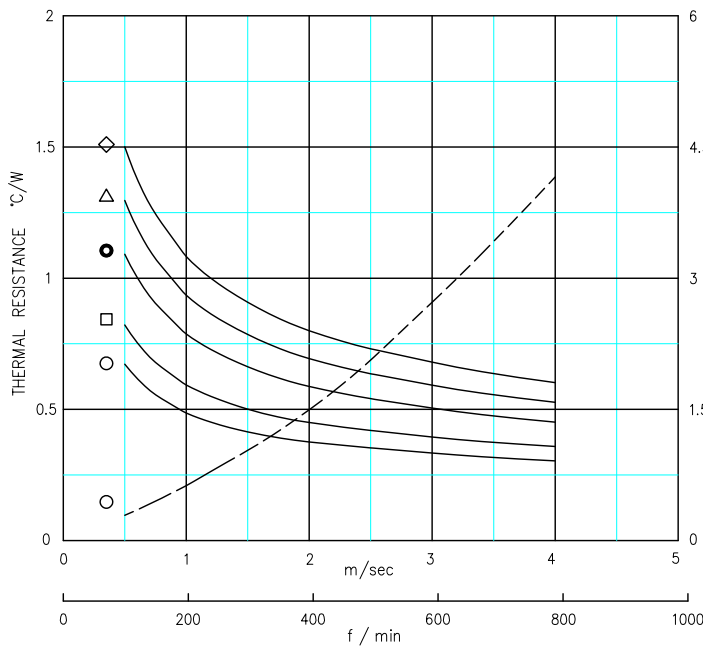

- ◇ ULP100-10B
- △ ULP100-12B
- ULP100-15B
- ULP100-20B
- ULP100-25B

● DUCTED CONDITION
 DUMMY HEATER SIZE: 25.4 SQ
 THERMAL RESISTANCE ———
 PRESURE DROP - - - - -

■ BASED ON ALPHA'S STANDARD TEST PROCEDURE.
 REFER TO TECHNICAL INFORMATION.

Alpha Company Ltd.

256-1 UEDA, NUMAZU-CITY SHIZUOKA-PREF., JAPAN
 PHONE +81(55)966 0789
 FAX +81(55)966 9192
 E mail : alpha@micforg.co.jp
 URL : <https://www.micforg.co.jp>

Alpha Novatech, Inc. - a subsidiary of Alpha Company.

473 Sapena Ct. #12 Santa Clara, CA 95054 USA
 PHONE +1(408)567-8082
 FAX +1(408)567-8053
 E mail : sales@alphanovatech.com
 URL : <https://www.alphanovatech.com>

ALPHA

Balance between low thermal resistance Low pressure drop

ULP120

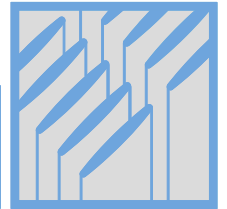

DIM

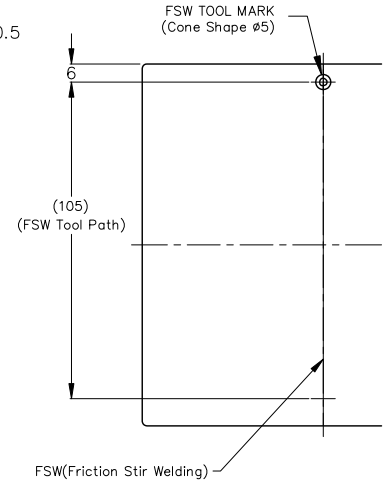
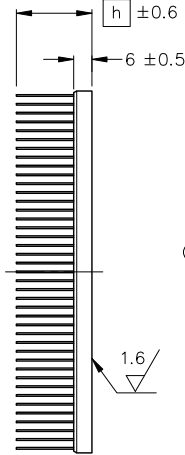
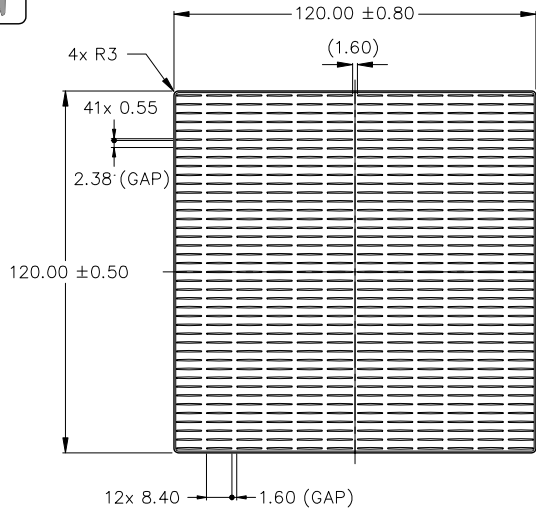

MATERIAL : A6063
 FINISH : BLACK ANODIZE
 DIMENSIONS : mm

MODEL	HEIGHT [h]	WEIGHT (grams)
ULP120-15B	15	280.8
ULP120-20B	20	307.5
ULP120-25B	25	334.2

DATA

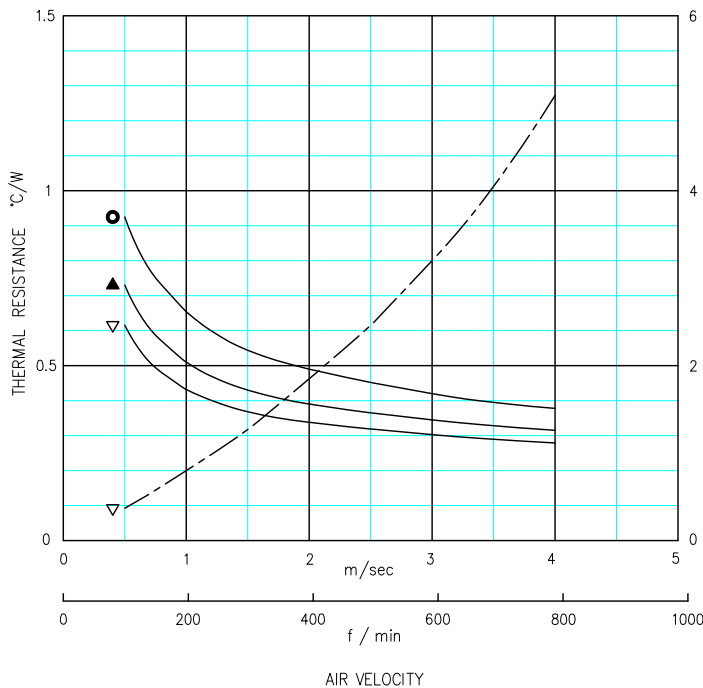

- ULP120-15B
- ▲ ULP120-20B
- ▽ ULP120-25B

- DUCTED CONDITION
- DUMMY HEATER SIZE: 25.4 SQ
- THERMAL RESISTANCE ———
- PRESURE DROP - - - - -

■ BASED ON ALPHA'S STANDARD TEST PROCEDURE.
 REFER TO TECHNICAL INFORMATION.

Alpha Company Ltd.

256-1 UEDA, NUMAZU-CITY SHIZUOKA-PREF., JAPAN
 PHONE +81(55)966 0789
 FAX +81(55)966 9192
 E mail : alpha@micforg.co.jp
 URL : <https://www.micforg.co.jp>

Alpha Novatech, Inc. - a subsidiary of Alpha Company.

473 Sapena Ct. #12 Santa Clara, CA 95054 USA
 PHONE +1(408)567-8082
 FAX +1(408)567-8053
 E mail : sales@alphanovatech.com
 URL : <https://www.alphanovatech.com>

ALPHA Balance between low thermal resistance Low pressure drop ULP12080

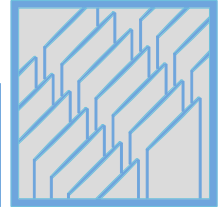

DIM

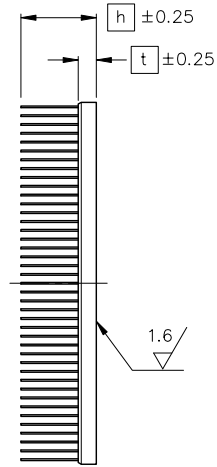
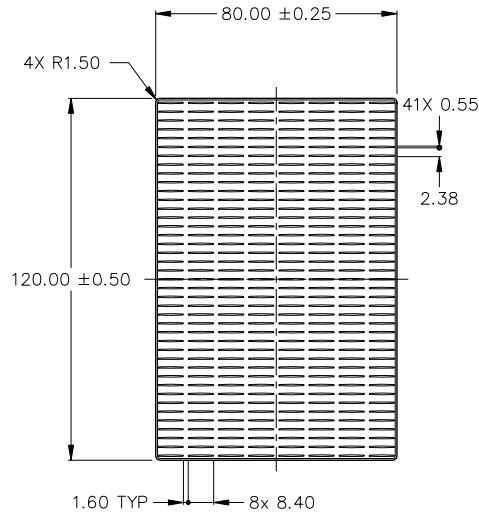

MATERIAL : A6063
 FINISH : BLACK ANODIZE
 DIMENSIONS : mm

MODEL	HEIGHT [h]	THICKNESS [t]	WEIGHT (grams)
ULP12080-10B	10	4.00	124.7
ULP12080-12B	12	5.00	154.2
ULP12080-15B	15	6.00	187.2
ULP12080-20B	20		205.0
ULP12080-25B	25		222.8
ULP12080-[h]B	$h \leq 10$	4.00	-
	$10 < h \leq 12$	5.00	-
	$12 < h \leq 25$	6.00	-

DATA

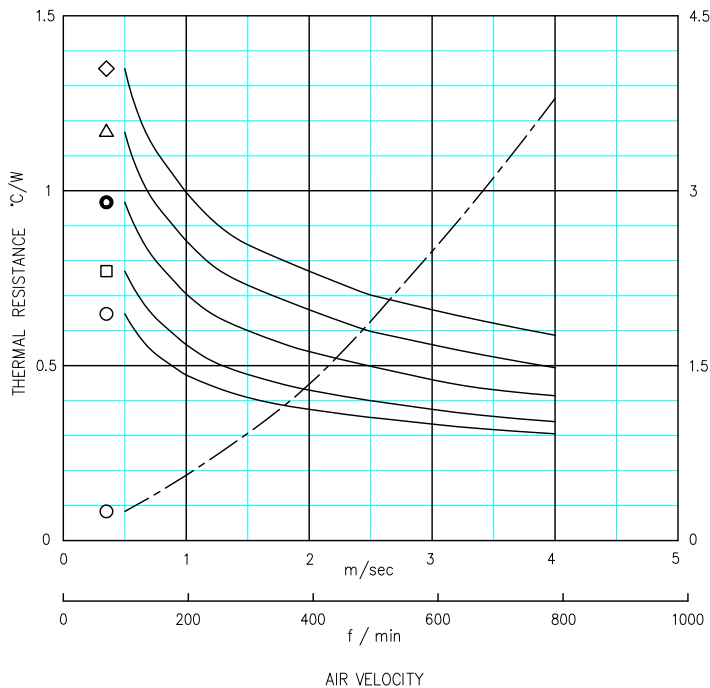

- ◇ ULP12080-10B
- △ ULP12080-12B
- ULP12080-15B
- ULP12080-20B
- ULP12080-25B

● DUCTED CONDITION
 DUMMY HEATER SIZE: 25.4 SQ
 THERMAL RESISTANCE ———
 PRESURE DROP - - - - -

■ BASED ON ALPHA'S STANDARD TEST PROCEDURE.
 REFER TO TECHNICAL INFORMATION.

Alpha Company Ltd.

256-1 UEDA, NUMAZU-CITY SHIZUOKA-PREF., JAPAN
 PHONE +81(55)966 0789
 FAX +81(55)966 9192
 E mail : alpha@micforg.co.jp
 URL : <https://www.micforg.co.jp>

Alpha Novatech, Inc. - a subsidiary of Alpha Company.

473 Sapena Ct. #12 Santa Clara, CA 95054 USA
 PHONE +1(408)567-8082
 FAX +1(408)567-8053
 E mail : sales@alphanovatech.com
 URL : <https://www.alphanovatech.com>