

【ZERO MASTER】 HEATSINK

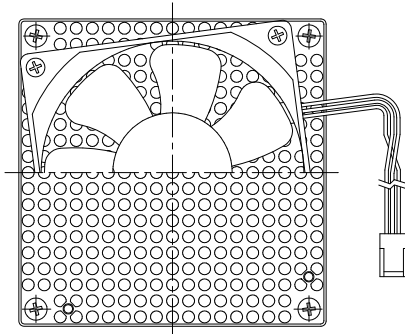

【TEST MASTER】 HEATSINK

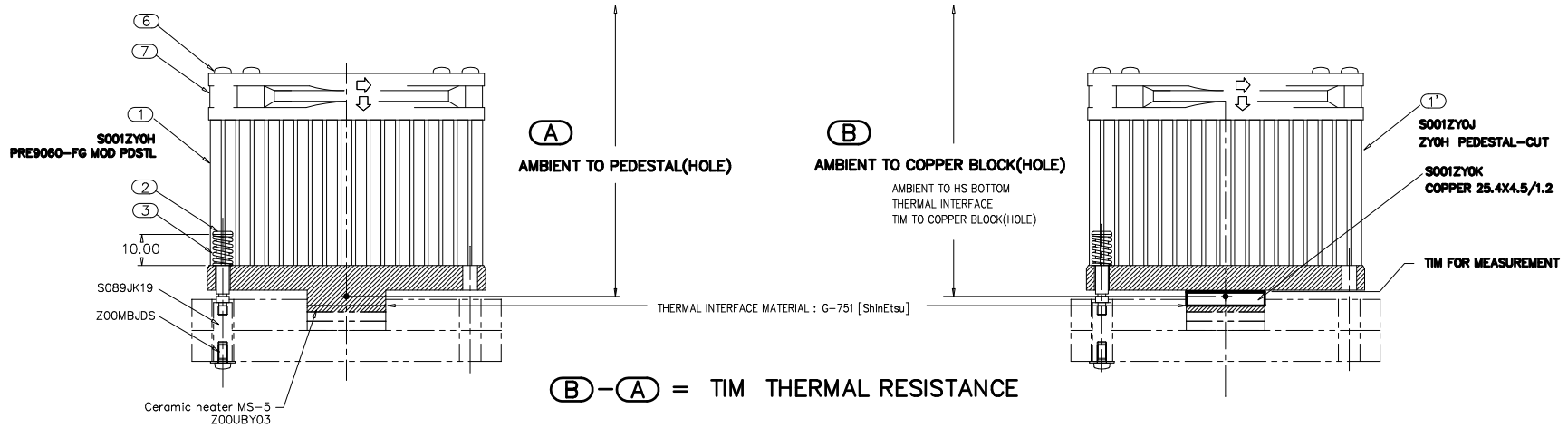
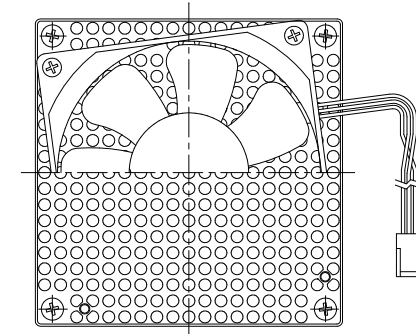

PCM: After setting up by the force to measure. The materials were initially warmed up to ~ 70degC, to ensure that phase change materials changed phase.

ADHESIVE TAPE: All tapes were installed per the instructions from each tape manufacturer. An additional 9.86PSI of pressure was applied to each piece of tape during the testing.

(7)	S001YQOL	FAN / M82	SANYO DENKI 109P0812M701 80SQ 15THICKNESS FAN 12V, 2000 RPM, 0.57m3/min, 1.29mmAq	1
(6)	S001ZC0D	M3x70(PAN HEAD)	PAN HEAD M3 70mm LENGTH STEEL ZINC/CHROMATE(Cr3+)	4

(3)	S001YJ3C	1.70 kgf	3.75 PSI	4	
	S001YJ2A	+0.1 washer	2.98		6.56
	S001YJ2Q		4.47		9.86
	S001YJ26		7.33		16.16
	S001YJ36		13.14		28.17
	S001YJ0Z		18.15		40.01
	S001YJ2L		30.84		67.98
(2)	S089HX0B	SS-22	STEEL ZINC/CHROMATE(Cr3+)	4	
ITEM	PART NO.	MODEL	REMARK	Q'TY	